

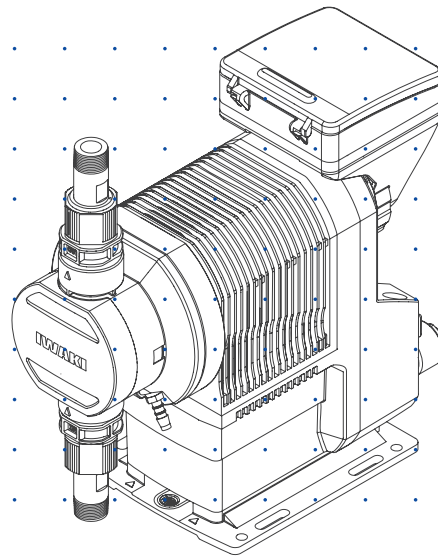

Hi-Techno Pump

IX-B series (North America)



Instruction manual

Thank you for choosing our product.

 Please read through this instruction manual before use.



This instruction manual describes important precautions and instructions for the product. Always keep it on hand for quick reference.

Order confirmation

Open the package and check that the product conforms to your order. If any problem or inconsistency is found, immediately contact your distributor.

a. Check if the delivery is correct.

Check the nameplate to see if the information such as model codes, discharge capacity and discharge pressure are as ordered.

Hi-Techno Pump	
MODEL	Acceptable for indoor use only
PRESSURE	Enclosure type 2
CAPACITY	Utilisation intérieure uniquement
VOLTAGE	Boîtier de type 2
CURRENT	Nonsubmersible Pump
POWER CONSUMPTION	Conforms to
FREQUENCY	ANSI/UL Std.778
MAX. LIQUID TEMP.	Certified to
MFG.No.	W CSA
	Std.C22.2 No.108
	Year :
IWAKI America Inc.	 US
	Intertek
	3111781

b. Check accessories are complete.

- A mounting adapter (pumps with TC/TE wet ends)

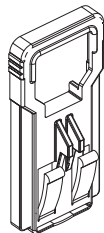

c. Check if the delivery is damaged or deformed.

Check for transit damage and loose bolts.

Contents

Order confirmation	2
Safety instructions.....	6
Warning	7
Caution.....	8
Precautions for use	10
Overview.....	12
Introduction	12
Pump structure & Operating principle	12
Features	13
Operational function.....	14
Manual mode	14
EXT mode	14
Analog proportional control.....	14
Pulse control	16
Batch control	16
Interval batch control.....	18
AUX function	18
Priming function	18
STOP functions	19
STOP function.....	19
Pre-STOP function.....	19
Analog output function	19
Protective functions.....	20
Interlock function.....	20
Diaphragm rupture detection	20
Pressure overload/Failed rotation control detection	20
Output functions	21
Alarm output function	21
Analog output function	21
Other functions.....	22
Suction speed setting.....	22
Maximum flow rate setting	22
Diaphragm position adjustment	22
Anti chattering setting	22
Output logic setting	22
Flow unit setting	22
Language setting	22
Keypad lock.....	22
Factory default setting.....	22
Part names.....	23
Pump.....	23

Operational panel.....	24
Basic displays & Pump states	25
Identification codes	26
Pump	26

Installation 27

Pump mounting	27
Floor mounting	27
Wall mounting.....	28
Mounting	28
Demounting.....	29
Console positioning	30
Control unit.....	30
Rear case.....	30
Plumbing	31
Piping layout.....	31
Tube connection.....	31
Drain port (Vent hole)	32
Wiring	33
End terminals	33
Power voltage/Earthing	34
Signal wire connection	35
EXT IN	36
STOP IN.....	36
AUX IN/Analog OUT	37
Alarm OUT (DIN connector).....	37

Operation..... 38

Before operation	38
Points to be checked	38
Retightening of pump head fixing bolts	38
Commissioning.....	39
Before a long period of stoppage (One month or more)	39
Perform a calibration.....	40
Calibration process	41
Operation setting	43
Setting flow chart	44
Menu screen	45
EXT mode selection.....	46
Calibration	48
Signal input setting.....	49
Analog output setting	50
Alarm output setting (OUT 1) <Mechanical relay>	51
Alarm output setting (OUT 2) <PhotoMOS relay>	53
Data logging	54
Setting of other functions	55

Operation	58
Manual operation	58
EXT operation	58
AUX function	59
Priming function	59
Keypad lock.....	60
Keypad lock activation	60
Keypad lock release.....	60
Emergency stop	60
Maintenance.....	61
Troubleshooting	62
Pump.....	62
Error messages	63
Inspection	63
Daily inspection	63
Periodic inspection	63
Wear part replacement	64
Wear part list	64
Before replacement.....	66
Valve set replacement.....	66
Diaphragm set replacement.....	67
Exploded view	71
Pump head, Drive unit & Control unit.....	71
Pump head.....	72
IX-B007/-B015/-B030/-B045 TC/TE R/N	72
IX-B007/-B015/-B030/-B045 TC/TE G.....	73
IX-B007/-B015/-B030/-B045 TC/TE F	74
IX-B007/-B015/-B030/-B045 TC/TE T	75
IX-B007/-B015/-B030/-B045 S6 R/N	76
IX-B007/-B015/-B030/-B045 S6 FJ/FD/FA	77
Specifications/Outer dimensions.....	78
Specifications	78
Pump.....	78
Control unit.....	79
Power cable	80
Body colour	80
Outer dimensions	81
IX-B007/-B015/-B030/-B045 TC/TE R/N	81
IX-B007/-B015/-B030/-B045 TC/TE G.....	82
IX-B007/-B015/-B030/-B045 TC/TE F	83
IX-B007/-B015/-B030/-B045 TC/TE T	84
IX-B007/-B015/-B030/-B045 S6 R/N	85
IX-B007/-B015/-B030/-B045 S6 FJ/FD/FA	86
Anchorage points guide (Wall-mount use of the base).....	87

Safety instructions

Read through this section before use. This section describes important information for you to prevent personal injury or property damage.

■ Symbols

In this instruction manual, the degree of risk caused by incorrect use is noted with the following symbols. Please pay attention to the information associated with the symbols.



WARNING

Indicates mishandling could lead to a fatal or serious injury accident.



CAUTION

Indicates mishandling could lead to personal injury or property damage.

A symbol accompanies each precaution, suggesting the use of "Caution", "Prohibited actions" and specific "Requirement".

Caution marks



Caution



Electrical shock

Prohibition mark



Prohibition



Do not remodel

Requirement mark



Requirement



Wear protectors



Earthing

Export Restrictions

Technical information contained in this instruction manual might be treated as controlled technology in your countries, due to agreements in international regime for export control.

Please be reminded that export license/permission could be required when this manual is provided, due to export control regulations of your country.

! WARNING

Electrical shock

Turn off power before service

Risk of electrical shock. Be sure to turn off power to stop the pump and related devices before service is performed.

Couper l'alimentation électrique de la pompe avant intervention

Intervenir sur la pompe sans avoir au préalable coupé l'alimentation électrique peut déclencher des décharges électriques. Avant d'entreprendre n'importe quel type d'intervention, veuillez à mettre la pompe et tout dispositif connexe hors tension à l'aide de l'interrupteur prévu à cet effet.



Requirement

Stop operation

If you notice any abnormal or dangerous conditions, suspend operation immediately and inspect/solve problems.

Arrêter le fonctionnement

Si vous détectez une anomalie ou des signes suspects et inhabituels pendant le fonctionnement, interrompez immédiatement les opérations et inspectez, résolvez les problèmes.



Prohibition

Do not use the pump in any condition other than its intended purpose

The use of the pump in any conditions other than those clearly specified may result in failure or injury. Use this product in specified conditions only.

Se conformer uniquement aux applications prévues

La pompe doit être utilisée conformément à l'usage pour lequel elle a été prévue et dans le respect de ses caractéristiques techniques. Toute utilisation non conforme peut entraîner un incident ou endommager le dispositif.



Do not remodel

Do not modify the pump

Alterations to the pump carries a high degree of risk. It is not the manufacturer's responsibility for any failure or injury resulting from alterations to the pump.

Ne pas modifier la pompe

Ne jamais modifier une pompe sous peine de causer un incident grave. Iwaki ne pourra en aucun cas être tenu responsable d'un incident ou de dégâts survenus à la suite d'une modification du dispositif.



Wear protectors

Wear protective clothing

Always wear protective clothing such as an eye protection, chemical resistant gloves, a mask and a face shield during disassembly, assembly or maintenance work. The specific solution will dictate the degree of protection. Refer to SDS precautions from the solution supplier.

Porter un équipement de protection

Toujours porter un équipement de protection (lunettes, gants résistants aux produits chimiques, masque, casque) durant le démontage, l'assemblage et la maintenance.

Le travail effectué dictera le degré de protection. Référez-vous au SDS de la solution proposée par le fournisseur.



Prohibition

Do not damage the power cable

Do not pull, knot, or crush the power cable. Damage to the power cable could lead to a fire or electrical shock if cut or broken.

Ne pas endommager le câble électrique

Ne pas tirer ou faire un nœud avec le câble électrique. Endommager un câble électrique peut provoquer un incendie ou une décharge électrique.



Prohibition

Do not operate the pump in a flammable atmosphere

Do not place explosive or flammable material near the pump.

Ne pas utiliser la pompe dans une atmosphère explosive

Pour votre sécurité, du matériel dangereux ou inflammable ne doit pas être placé près de la pompe.



Risk of electric shock

This pump is supplied with a grounding conductor and grounding-type attachment plug. To reduce the risk of electric shock, be certain that it is connected only to a properly grounded, grounding type receptacle.

Risque de choc électrique

La pompe est fournie avec un conducteur pour mise à la terre et une prise courant. Afin de réduire le risque de choc électrique, veillez à ce que la terre soit correctement raccordée.

⚠ CAUTION



Qualified personnel only

The pump should be handled or operated by qualified personnel with a full understanding of the pump. Any person not familiar with the product should not take part in the operation or maintenance of the pump.

Opérateur qualifié uniquement

La pompe doit être manipulée ou utilisée par du personnel qualifié connaissant parfaitement la pompe. Tout autre personne étrangère ne doit pas prendre part à l'utilisation ou à la maintenance de la pompe.



Use specified power only

Do not apply power other than that specified on the nameplate. Otherwise, failure or fire may result. Ensure the pump is properly grounded.

Utilisez une tension appropriée uniquement

Ne pas appliquer une autre tension que celle spécifiée sur la plaque signalétique sinon, il peut en résulter une panne ou une incendie. Assurez-vous également de la mise à la terre de la pompe.



Keep electric parts and wiring dry

Risk of fire or electric shock. Install the pump where it can be kept dry.

Ne mouillez pas les parties électriques ou les câbles

Risque d'incendie ou de décharge électrique. Installez la pompe dans un endroit sec.



Ventilation

Fumes or vapors can be hazardous with certain solutions. Ensure proper ventilation at the operation site.

Ventilation

Manipuler un produit toxique ou odorant peut provoquer une intoxication. Prévoyez une ventilation suffisante à l'endroit de la manipulation.



Do not install or store the pump:

- In a flammable atmosphere.
- In a dusty/humid environment.
- Where ambient temperature can exceed 0-50°C (32-122°F).
- In direct sunlight or wind & rain.

N'installez ou ne stockez pas la pompe dans les endroits suivantes:

- Dans une atmosphère inflammable
- Dans un endroit poussiéreux ou humide.
- Dans une place où la température n'est pas comprise entre 0 et 50 °C.
- Directement sous le soleil, le vent ou la pluie.



This pump has been evaluated for use with water only.
Cette pompe a été testée uniquement avec de l'eau.



Requirement

Spill precautions

Ensure protection and containment of solution in the event of plumbing or pump damage (secondary containment).

Déversement accidentel

Prenez des mesures protectrices contre tout incident résultant d'un débit trop important de la pompe ou d'une casse de tuyauterie.



Prohibition

Do not use the pump in a wet location

The pump is not waterproof. Use of the pump in wet or extremely humid locations could lead to electric shock or short circuit.

N'utilisez pas la pompe sous l'eau

La pompe n'est pas complètement étanche. Utiliser la pompe dans l'eau ou dans un endroit très humide peut créer une décharge électrique ou un court-circuit.



Earthing

Grounding

Risk of electrical shock! Always properly ground the pump. Conform to local electric codes.

Mise à la terre

Veillez à ne pas faire fonctionner la pompe sans avoir au préalable prévu une mise à la terre. Celle-ci permettra d'éviter d'éventuelles décharges électriques. Vérifiez que le câble de mise à la terre est bien branché.



Electrical shock

Install a GFCI (earth leakage breaker)

An electrical failure of the pump may adversely affect other devices on the same line. Purchase and install a GFCI (earth leakage breaker) separately.

Détecteur de fuites à la terre

Un problème électrique peut affecter défavorablement le dispositif. Achetez et installez un détecteur de fuites à la terre.



Requirement

Preventative maintenance

Follow instructions in this manual for replacement of wear parts. Do not disassemble the pump beyond the extent of the instructions.

Remplacement des pièces usées

Suivez les instructions de ce manuel pour remplacer les pièces usées. Ne démontez pas la pompe au-delà des instructions.



Prohibition

Do not use a damaged pump

Use of a damaged pump could lead to an electric shock or death.

N'utilisez pas une pompe endommagée

Utiliser une pompe endommagée peut provoquer une décharge électrique ou la mort.



Requirement

Disposal of a used pump

Dispose of any used or damaged pump in accordance with local rules and regulations. If necessary, consult a licensed industrial waste disposal company.

Elimination des pompes usées

Elle doit se faire en conformité avec les règles locales en vigueur (consultez une entreprise certifiée et spécialisée).



Caution

Check pump head bolts

Liquid may leak if any of the M5 pump head bolts become loose. Remove the bolt cover and tighten the bolts diagonally and evenly by 3.0N•m before initial operation and at regular intervals.

Serrez la tête de pompe

Il pourrait y avoir une fuite de liquide si les 4 boulons M5 du corps de pompe ne sont pas bien serrés. Enlevez le cache boulon et resserrez les boulons diagonalement et uniformément 3.0N•m avant la première utilisation et à intervalles réguliers.

Precautions for use

- Electrical work should be performed by a qualified electrician. Otherwise, personal injury or property damage could result.

Le raccordement électrique de la pompe doit être effectué par du personnel qualifié sinon, il pourrait y avoir un dommage corporel ou incorporel.



- Do not install the pump:
 - In a flammable atmosphere.
 - In a dusty/humid place.
 - In direct sunlight or wind & rain.
 - Where ambient temperature can exceed 0-50°C (32-122°F).

Ne pas installer la pompe dans les endroits suivants:

- Dans une atmosphère inflammable
- Dans une atmosphère poussiéreuse ou humide.
- Sous les rayonnements du soleil, dans le vent ou sous la pluie.
- La température ambiante doit être comprise entre 0 et 50°C.

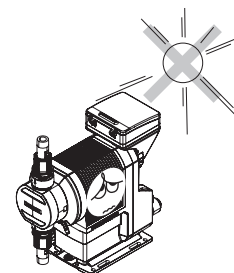

- Select a level location, free from vibration, that won't hold liquid. Anchor the pump with four M8 bolts so it doesn't vibrate. If the pump is not installed level, output may be affected.

Choisissez un endroit où il n'y a pas de vibrations et où le liquide peut s'évacuer. Fixez la pompe à l'aide de vis M8 de façon à ne pas avoir de vibrations. Si la pompe est inclinée, le débit peut être réduit.

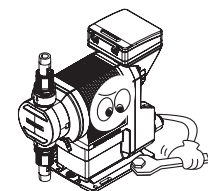

- When two or more pumps are installed together, vibration may be significant, resulting in poor performance or failure. Select a solid foundation (concrete) and fasten anchor bolts securely to prevent vibration during operation.

Si plusieurs pompes sont installées ensemble, elles interagissent et les vibrations peuvent devenir importantes, ce qui engendre des performances médiocres ou des ratés. Choisissez un endroit solide et fixez les boulons correctement pour éviter les vibrations pendant le fonctionnement.



- Allow sufficient space around the pump for easy access and maintenance. Prévoyez de l'espace autour de la pompe pour faciliter l'accès et la maintenance.



- Install the pump as close to the supply tank as possible. Installez la pompe le plus près possible du tank de produit.



- When handling liquids that generate gas bubbles (sodium hypochlorite or hydrazine solution), install the pump in a cool and dark place. Flooded suction installation is strongly recommended.

Installez la pompe dans une place froide à l'abri du soleil lorsqu'il s'agit du dosage de produits dégazant tels que l'hypochlorite de sodium ou l'hydrazine. Mettre la pompe en charge est vivement recommandé.



- The suction line I.D. should be equal to or wider than the I.D. of the pump. La ligne d'aspiration doit être plus large que l'entrée de la pompe.



- Build up a flooded suction system for the viscous liquid delivery of 50mPa·S or more.

Pour les liquides ayant une viscosité supérieure ou égale à 50 mPa.s il faut mettre la pompe en charge.



- Use measures to keep the pump connections free from stress. Weight and thermal expansion/contraction of the piping can stress connection points.

La pompe ne doit pas être soumise à des effets éventuels de dilation ou de contraction du pipe dus à un stress thermique.



Caution

- Overload protection will stop pump operation when discharge pressures reach 1.2 to 1.5 times higher than the pump maximum. If the discharge line cannot conservatively handle the maximum pressure, use a relief valve to safely depressurize the discharge line.

Un dispositif de protection en cas de surcharge doit pouvoir arrêter le dosage quand la pression au refoulement s'élève de 1,2 à 1.5 fois le maximum admis. Installez une vanne de sécurité pour relâcher la pression de la ligne de refoulement si la ligne de refoulement ne peut pas supporter de haute pression.



Caution

- Use care handling the pump. Do not drop. An impact may affect pump performance. Do not use a pump that has been damaged to avoid the risk of electrical damage or shock.

Veillez à ne pas laisser tomber la pompe sur le sol. Un impact important pourrait réduire les performances de la pompe. Ne pas utiliser une pompe endommagée sinon il pourrait y avoir un courant de fuite ou une décharge électrique.

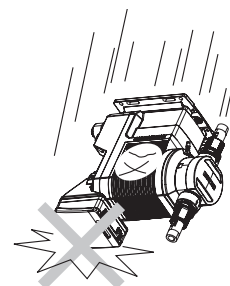

- The pump has a rating of IP65 equivalent, but is not waterproof. Do not operate the pump while wet with solution or water. Failure or injury may result. Immediately dry off the pump if it gets wet.

La pompe est IP65 équivalent mais n'est pas complètement étanche. Ne pas laisser la pompe couverte de liquide pompé ou sous la pluie. Il pourrait y avoir des ratés ou préjudices. Si la pompe a été mouillée, sechez-la directement.



Caution

- Do not close discharge line during operation. Solution may leak or pump and piping may break. Install a relief valve to ensure safety and prevent damaged plumbing.

Ne fermez pas la ligne de refoulement lorsque la pompe est en fonctionnement sinon il pourrait y avoir des fuites de liquide ou la pompe et la tuyauterie pourraient céder. Installez une soupape de sécurité pour des raisons de sécurité et pour éviter tout dommage de la tuyauterie.



Requirement

- Solution in the discharge line may be under pressure. Release the pressure from the discharge line before disconnecting plumbing or disassembly of the pump to avoid solution spray.

Le liquide au refoulement peut être sous pression. Relâchez la pression du refoulement avant de démonter la pompe ou d'enlevez le tubage pour éviter tout jet de liquide.



Requirement

- Wear protective clothing when handling or working with pumps. Consult solution SDS for appropriate precautions. Do not come into contact with residual solution.

Portez un équipement de sécurité lorsque vous manipulez la pompe. Consultez le SDS pour utilisez les précautions appropriées. Evitez tout contact avec le liquide chimique.



Caution

- Do not clean the pump or nameplate with a solvent such as benzine or thinner. This may discolour the pump or erase printing. Use a dry or damp cloth or a neutral detergent.

Ne nettoyez pas la pompe ou la plaque signalétique à l'aide d'un solvant comme le benzène ou le white spirit. Cela pourrait décolorer la pompe ou effacer l'impression. Utilisez un tissu sec ou mouillé avec de l'eau ou un détergent neutre.



Overview

Pump characteristics, features and part names are described in this section.

Introduction

Pump structure & Operating principle

The IX series are diaphragm pumps with a brushless DC (BLDC) motor and feature a high turndown ratio & automatic controls.

Principle of operation

In the IX series design, a BLDC motor rotation controls the flow rate.

Motor rotation is transmitted to an eccentric cam through a reduction gear and then converted to reciprocating motion. Volumetric change occurs in the pump chamber as the diaphragm moves back and forth and liquid is pumped because of the suction and discharge check valves. Discharge speed changes the flow rate while the suction speed remains the same at any flow rate.

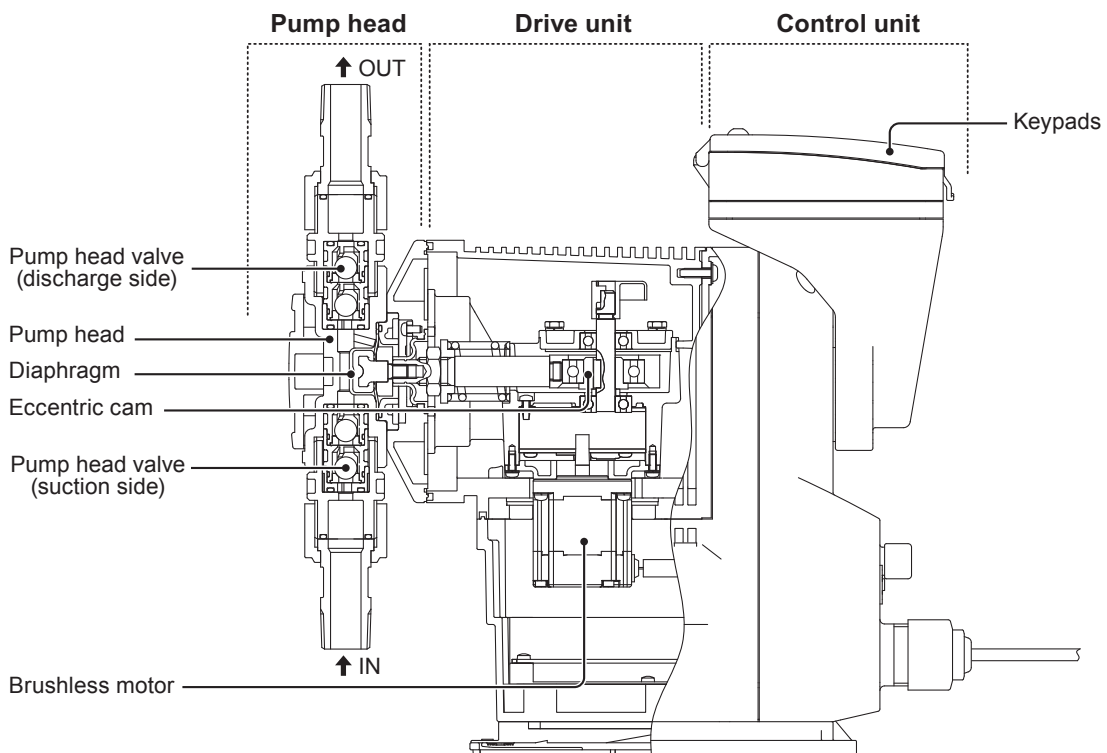

Features

- **High turndown ratio**

Use of a BLDC control motor enables accurate control with a wide turndown ratio.

- **High repeatability**

Highly-efficient valve design and accurate discharge-/suction-speed controls assure the high repeatability of chemical dosing ($\pm 1\%$).

- **Energy-saving design**

Use of helical gears and an assist spring reduces power consumption.

- **Automatic control**

The IX can automatically run along with analog-, pulse-, batch- or interval batch-operation setting.

- **Multivoltage operation**

The IX series can be used in all countries thanks to the universal power voltage (100-240VAC).

- **Safety design**

A diaphragm rupture detection ensures user safety and a pressure overload detection protects the pump and pipework from an accidental discharge line pressure rise.

- **Ingress protection rating of IP65**

- **User-friendly design**

The rear case itself as well as the operation panel can be turned around to the best position.

- **Wall-mount/Floor-mount options**

The detached pump base is the wall-mounting bracket to hold the pump onto the wall.

- **Fool-proof design (valve set)**

The fool-proof design prevents the valve set installed upside down which upsets the pump operation.

- **Adhesive-free diaphragm**

The adhesive free "full-PTFE" diaphragm and so improved immunity to chemical attack.

- **LED bar**

The large LED bar on the control unit assists in knowing various operating status and alarm conditions.

Operational functions

Manual mode

Run/stop the pump by key operation. The flow rate can be changed by the up and the down keys at any time during operation or stop. The green LED bar lights during operation. See page 58 for detail.

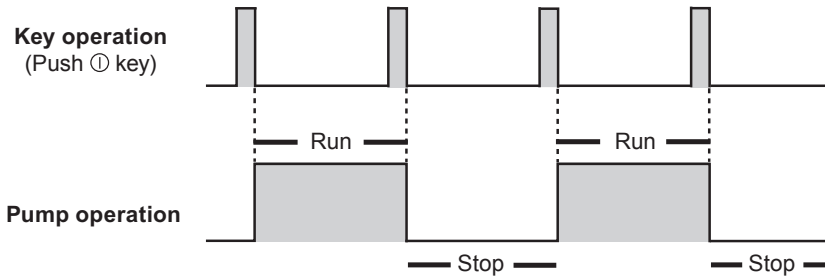

EXT mode

■ Analog proportional control

ANA. P (analog preset) setting (see page 46 & 58)

Select a proportional control pattern. 4 - 20mA, 20 - 4mA, 0 - 20mA and 20 - 0mA are available. During operation, the display shows the current flow rate. To show the current value, push the \rightarrow key. To return to the flow rate display, push the \leftarrow key.

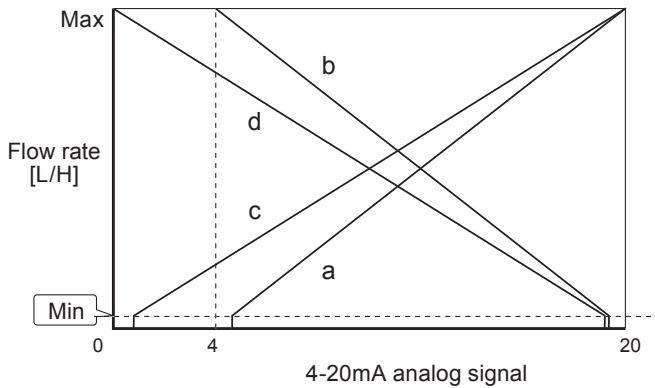

The left graph shows the flow rate at each pattern.

- a. 4 - 20mA
- b. 20 - 4mA
- c. 0 - 20mA
- d. 20 - 0mA

*The flow rate falls to 0mL/H if the pump runs beneath the minimum rate.

*The pump does not run over the maximum flow rate at any current value.

Example of use: pH control in a water treatment system

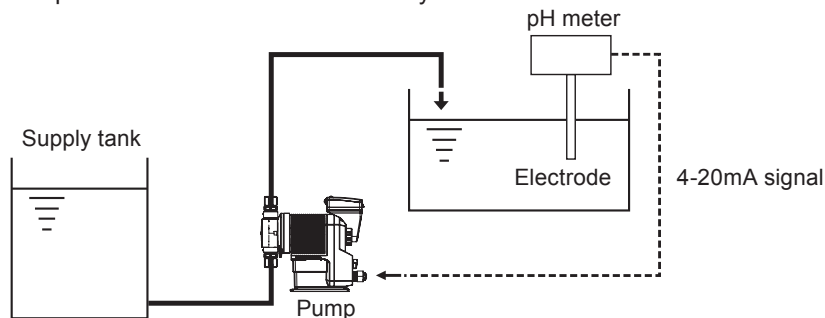

ANA. V (analog variable) setting (see page 46 & 58)

The pump increases/decreases a stroke/flow rate in proportion to 0-20mA. Determine the operational behavior by setting two set points and choosing one of the LINEAR, BOX and LIMIT patterns.

To show the current value, push the → key. To return to the flow rate display, push the ← key.

<LINEAR>

A stroke/flow rate changes with a current value by a set line.

Condition:

Set Point 1 (SP.1) = Ampere : 6mA, Flow rate : 4.5L/H

Set Point 2 (SP.2) = Ampere : 17mA, Flow rate : 12.7L/H

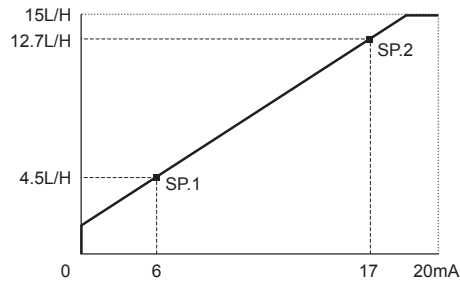

<BOX>

A stroke/flow rate changes with a current value by a set line. The rate does not exceed the Set Point 2 but then falls to 0 before the Set Point 1.

Condition:

Set Point 1 (SP.1) = Ampere : 6mA, Flow rate : 4.5L/H

Set Point 2 (SP.2) = Ampere : 17mA, Flow rate : 12.7L/H

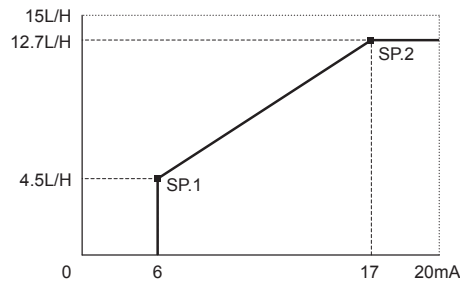

<LIMIT>

A stroke/flow rate changes with a current value by a set line. The rate does not fall below the Set Point 1 or exceed the Set Point 2.

Condition:

Set Point 1 (SP.1) = Ampere : 6mA, Flow rate : 4.5L/H

Set Point 2 (SP.2) = Ampere : 17mA, Flow rate : 12.7L/H

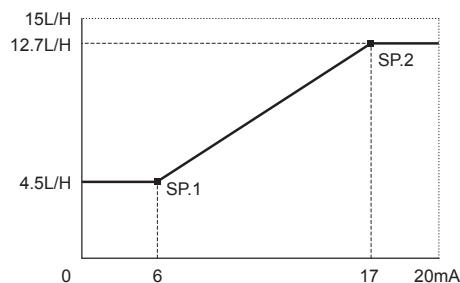

■ **Pulse control (see page 46 & 58)**

The flow rate is automatically controlled by the flow volume (ml) per pulse and the pulse signal frequency from a flow meter.

*It takes about 10 seconds for the IX to catch up with the change of the frequency. In other words, the pump stops 10 seconds after the pulse signal is stopped. Use the external interlock (or stop) signal to turn off the pump with no delay.

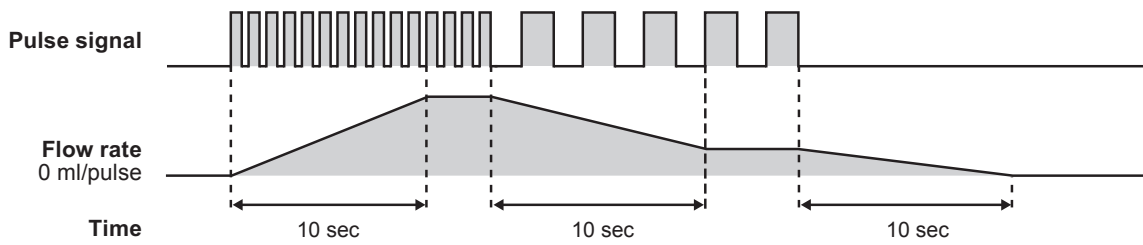

Example of use: Chemical dosing in a sewage treatment system

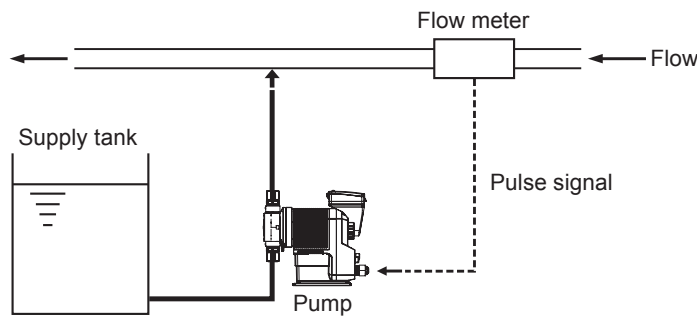

■ **Batch control (see page 46 & 58)**

The IX discharges a preset flow volume per pulse and stops when it is completed. The preset or remaining flow volume is shown on the controller until it has reduced to zero. In this control mode, the pump runs at the MAN speed (the pump speed in the manual mode). The pump behaviour can change depending on the setting of the buffer. See below.

When the buffer is OFF:

Any input of the external pulse signal will be cancelled when the pump is activated for the earlier pulse input. The next dosing becomes ready after the preset flow volume has been completed.

*Note the control stops immediately when the  key is pushed once.

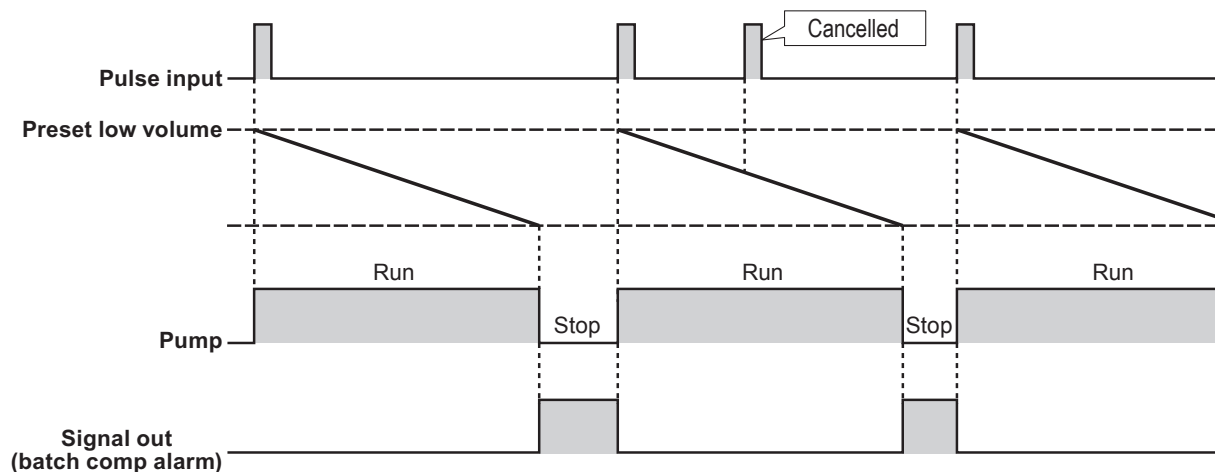

When the buffer is ON:

Every time the external pulse signal is inputted, the preset flow volume per pulse is accumulated (max 65535 pulses) even when the pump is activated for the earlier pulse input.

*The control stops immediately and all the pulse accumulation is cleared when the  key is pushed once.

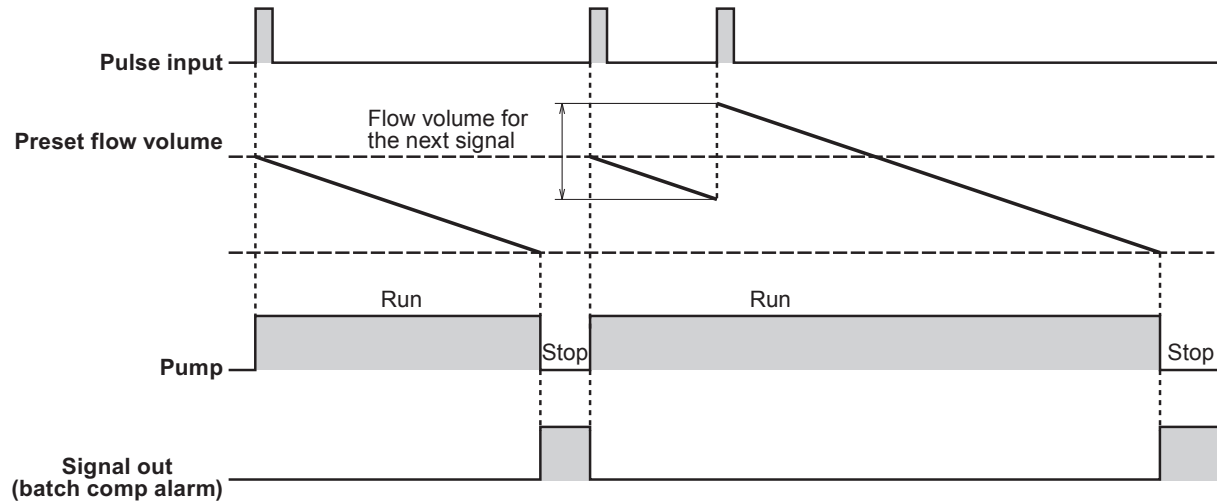

Pulse input by the  key:

Instead of the pulse signal input, pushing the  key can start or stop the batch control. In this case, the pump behaves as the control with the buffer OFF even when the buffer is set to ON in the batch control mode.

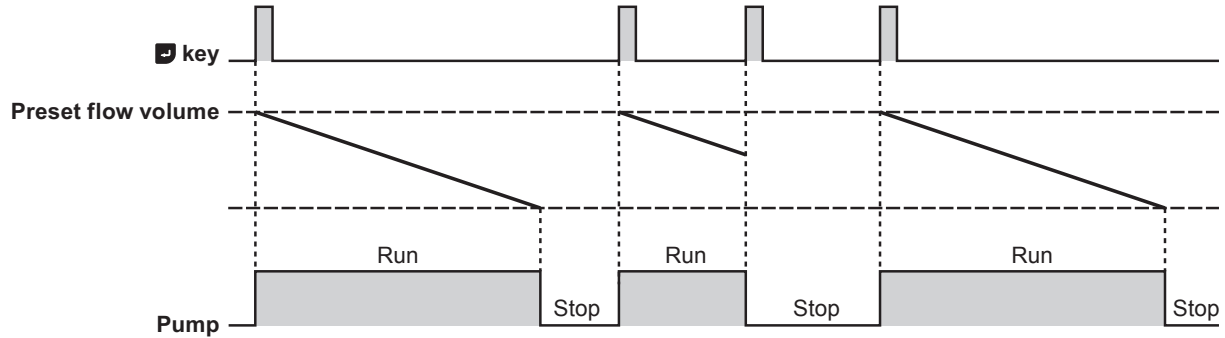

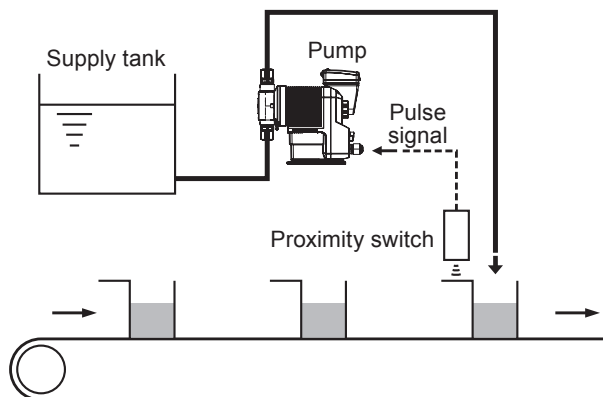

Example of use: Chemical dosing in a production line system



■ Interval batch control (see page 46 & 58)

To make an interval batch control, set a date and time interval and the flow volume. The IX discharges the pre-set flow volume at a set interval. In the diagram below, the interval is set to 1 hour.

*The pump runs at the MAN speed. The control is triggered by either the external pulse signal or the push of the  key. Push the  key to stop the control when it is triggered by the  key.

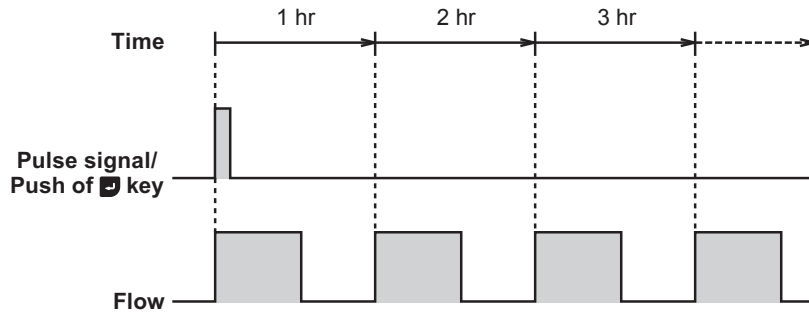

Example of use: Water transfer for a sprinkler system

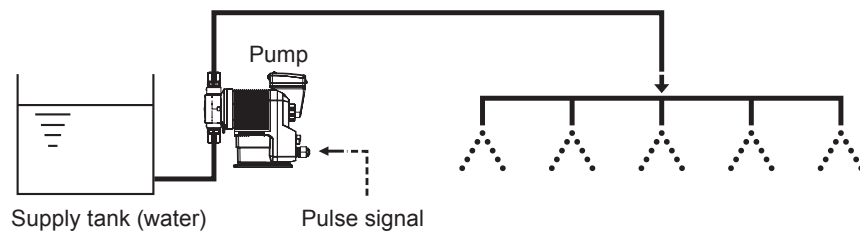

AUX function

The pump runs at the AUX speed while receiving the external signal via the AUX terminal. See page 55.

*This function works only when the pump is running in either MAN or EXT mode (see page 44.). The pump returns to the MAN or EXT mode once the AUX signal stops.

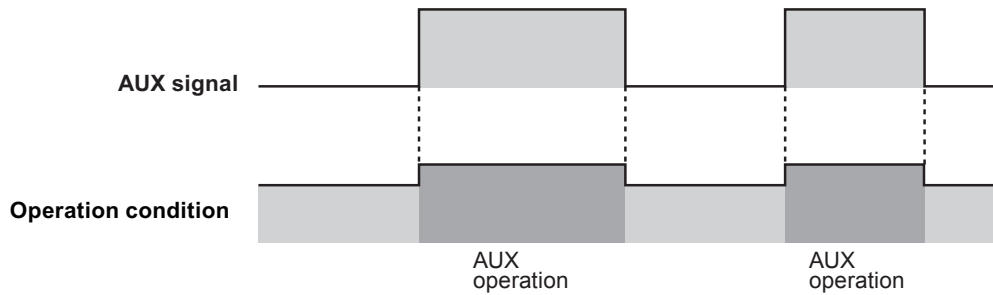

Priming function

The pump runs at the preset maximum flow rate (or the maximum stroke rate with the factory default setting) while both the UP and DOWN keys are pressed. Use this function for priming or degassing. The pump returns to normal flow rate after both the keys are released. See page 59 for detail.

*This function is available at any time except when the pump is in the MAN/EXT selection or menu selection (see page 44.).

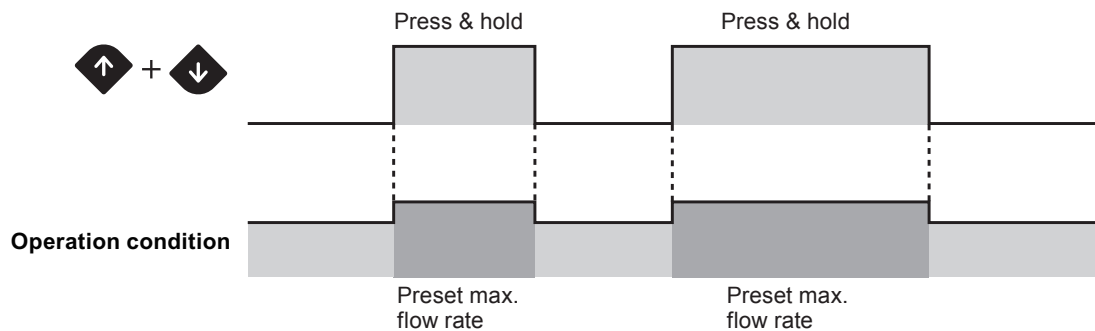

STOP functions

■ STOP function (see page 49)

The start/stop of operation can be controlled by the signal from a level sensor. The LED bar changes from orange to purple colour when the pump is receiving the STOP signal from a level sensor in operation. See the "STOP IN" paragraph on page 36 for wiring diagram.

Example of use: Liquid level monitoring

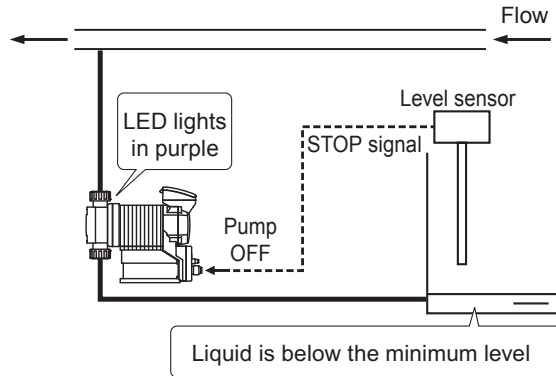

The pump stops when liquid has fallen below the minimum level.

■ Pre-STOP function (see page 49)

The liquid level in the supply tank can be monitored by the signal from a level sensor. The LED bar changes from green to orange colour when the pump is receiving the Pre-STOP signal from a level sensor in operation. See the "STOP IN" paragraph on page 36 for wiring diagram.

Example of use: Liquid level monitoring

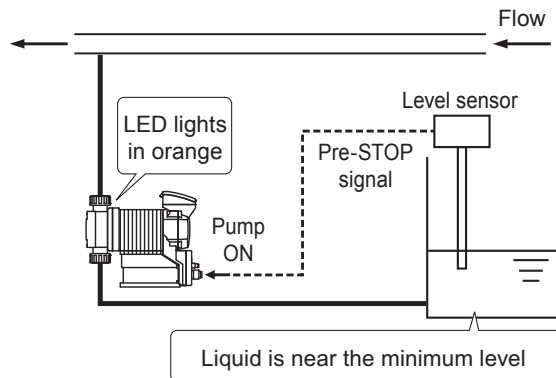

The orange LED bar lights to inform a user that liquid comes close to the minimum level in a supply tank.

Protective functions

■ Interlock function (see page 36 & 51)

The interlock function works in the same way as the STOP function. Use this function for an emergency stop.

■ Diaphragm rupture detection (see page 49)

The pump stops right after a built-in sensor detects a leak in the compartment at the back of the diaphragm. In this condition, the red LED bar will flash. Replace a broken diaphragm as necessary. See page 67 for diaphragm replacement. To release this error condition, push the start/stop key.

NOTE

- This capacitance sensor does not work properly if liquid conductivity is 1mS/m or below. Before sending pure water, oil or any other low-conductivity liquid, check the conductivity to see if it meets the minimum detection level. If it is not satisfied, the leak sensor is no longer usable. In this case a leak from the drain port is the only valid indicator. In either case, replace the diaphragm immediately when a leak is found.
- When the liquid temperature is much lower than the room temperature where the pump is installed, condensed water can build up in the compartment at the back of the diaphragm and the built-in leak sensor there can stop the pump even when no leak has occurred. Reduce the temperature difference between the liquid temperature and the room temperature or disable the "Leak Detection" option to remove this issue.

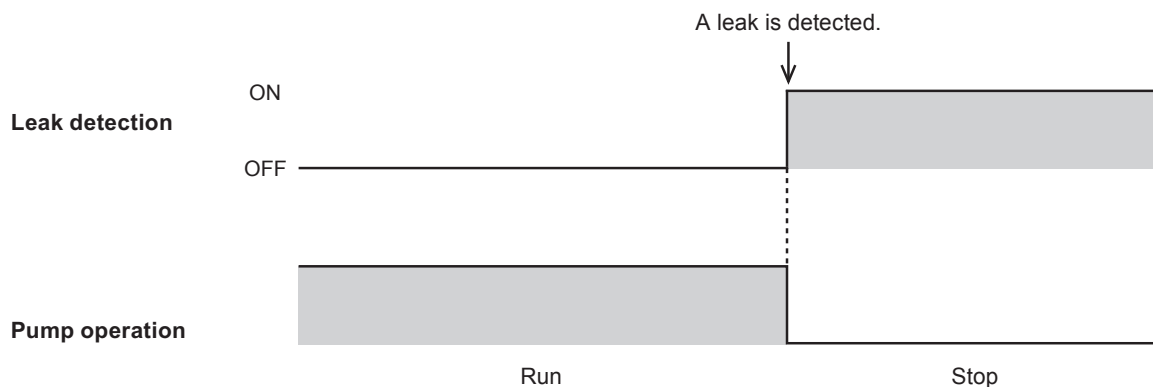

■ Pressure overload/Failed rotation control detection

The pump stops and the red LED bar flashes when a controller circuit board detects 1.2-1.5 times higher discharge pressure than the maximum level or when the hole IC which monitors the motor rotation has failed. If the pump is suspended (by the over-current protection) in either condition, the pump resumes operation 30 seconds later. If the suspended operation has recurred 5 times consecutively, the pump will not resume operation any more and will keep still. These error conditions can be released when the start/stop key is pushed once.

NOTE

The discharge pressure can rise 1.2-1.5 times higher than the maximum allowable level of the pump depending on operating conditions and piping layouts. If the pressure rises too sharp (with the closed discharge), it may not be even detected or curbed by the over-current protection. Set up a relief valve to protect the related devices on the discharge line from the possible pressure rise if necessary.

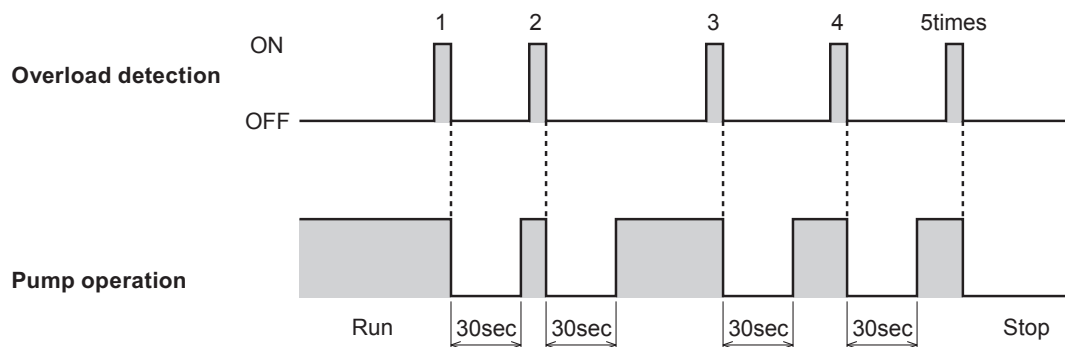

Output functions

■ Alarm output function (see page 51)

Enable or disable the output of the batch completion, STOP, Pre-STOP, interlock, diaphragm rupture detection, pressure overload detection, and/or drive error detection functions which is preset to the Alarm OUT 1 and 2, or the output of the volume proportional pulse which is preset only to the Alarm OUT 2. See the "Alarm OUT (DIN connector)" paragraph on page 37 for wiring diagram.

Alarm OUT 1 (OUT 1) : Mechanical relay output (no voltage contact 1a×1 250VAC 3A, resistive load)

Alarm OUT 2 (OUT 2) : PhotoMOS relay output (no voltage contact 1a×1 24VAC/DC 0.1A, resistive load)

*If the batch completion output is enabled to the Alarm OUT 1 or 2 (or if the volume proportional pulse output enabled only to the Alarm OUT 2), the other outputs (STOP, Pre-STOP, interlock, diaphragm rupture detection, pressure overload detection, and drive error detection) turn disabled in that Alarm OUT.

*The other outputs (STOP, Pre-STOP, interlock, diaphragm rupture detection, pressure overload detection, and drive error detection) can be enabled together (to the Alarm OUT 1 or 2), sharing the same output signal. See the controller display to tell which the signal it is.

*With the factory default setting, the range of the volume proportional pulse output is between 1Hz (at the min flow of the pump) and 200Hz (at the max flow rate of the pump). The max flow rate is manually reduced as shown below through the "Pump Max Rate" options in the "Other Features" menu.

IX-B007: Volume proportional pulse output behaviour

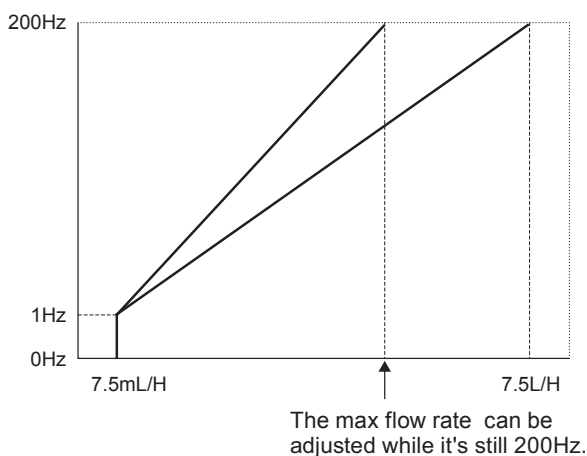

■ Analog output function (see page 50)

The pump transmits the 0-20mA analog signal in proportion to the preset flow rates (set point 1 and 2).

*If the actual flow has fallen below the minimum flow at each model (see page 78), the amperage goes down to the 0L/H level.

*The amperage does not fall below 0mA or exceed 20mA at any setting of the set point 1 and 2.

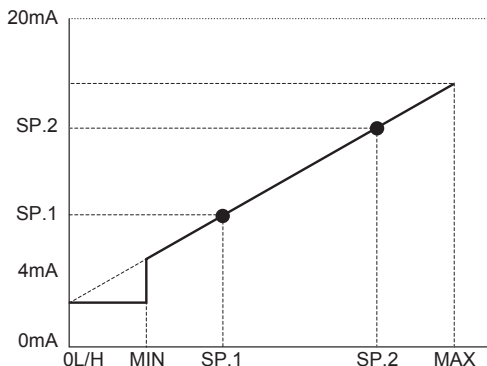

Other functions

■ Suction speed setting (see page 55)

Suction speed is adjustable by 4 levels depending on liquid property. Reduce suction speed so as to reduce inertia resistance for the delivery of viscous liquid or to prevent cavitation for gaseous liquid. Select 100% (default), 75%, 50% or 25%.

*The max flow rate of the pump (determined through the "Pump MAX Rate" or "Pump AUX Rate" options) goes down to an appropriate level automatically when the suction speed is reduced from 100% to 75%, 50%, or 25%. Recover the max flow rate manually if the suction speed is returned (/increased).

■ Maximum flow rate setting (see page 55)

The maximum allowable flow rate of the IX can be reduced if necessary. The factory default setting of the IX-B007: 7.5L/H, IX-B015: 15L/H, IX-B030: 30L/H, and IX-B045: 45L/H.

■ Diaphragm position adjustment (see page 55)

A pump shaft expands or contracts for easy diaphragm replacement. Select the "MAX OUT Pos." option through the "Other Features" menu in order to extend the pump shaft to the maximum. Select the "MAX IN Pos." option to contract it to the minimum and mount the pump head. See the "Diaphragm replacement" section on page 67 for detail.

■ Anti chattering setting (see page 55)

Set a pulse recognition time for the IX not to be adversely affected by chattering or noise. The factory default setting is 5 msec. This means the pump recognizes the pulse length of 5 msec or more. The other options are 1 and 2 msec and should be selected for the shorter pulse length, however, note the shorter the recognition time is, the more susceptible to the interference of noise the pump becomes. Note the maximum allowable input frequency of the IX is 100Hz.

■ Output logic setting (see page 55)

Select "normally open" or "normally closed" for the Alarm OUT 1 (OUT 1) and 2 (OUT 2) outputs.

■ Flow unit setting (see page 55)

Select L/H or GPH for the flow rate indication.

■ Language setting (see page 55)

Select your language through the language selection.

■ Keypad lock (see page 60)

The IX-C is shipped with the access codes at default values (00000). In order to prevent against unauthorized tampering, you will need to change the access codes to your own values.

■ Factory default setting

Power on the pump while pressing the ESC key to recall the factory default setting. Note the flow volume per shot obtained through the calibration process (see page 41) remains the same.

Part names

Pump

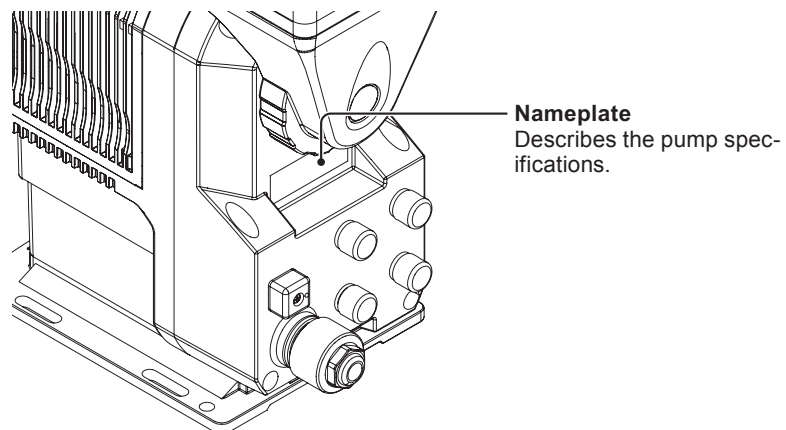
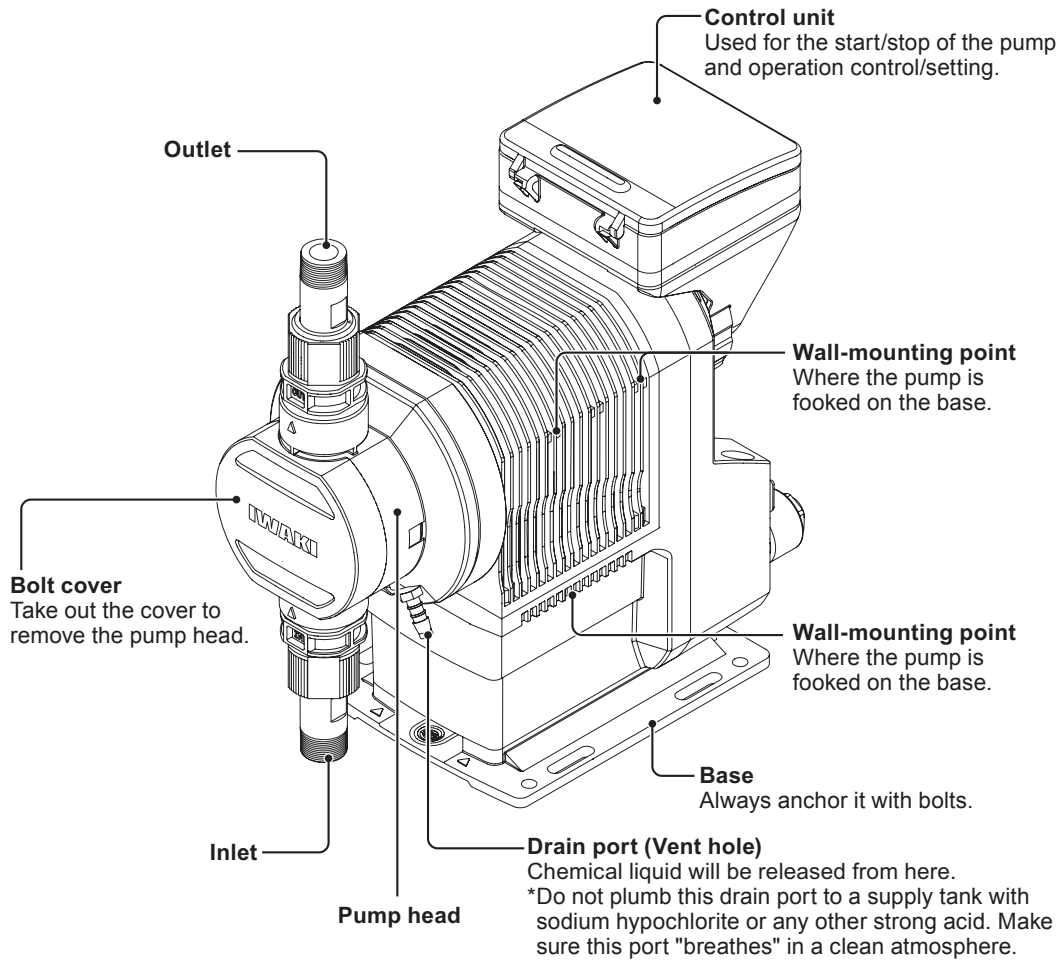

Operation panel

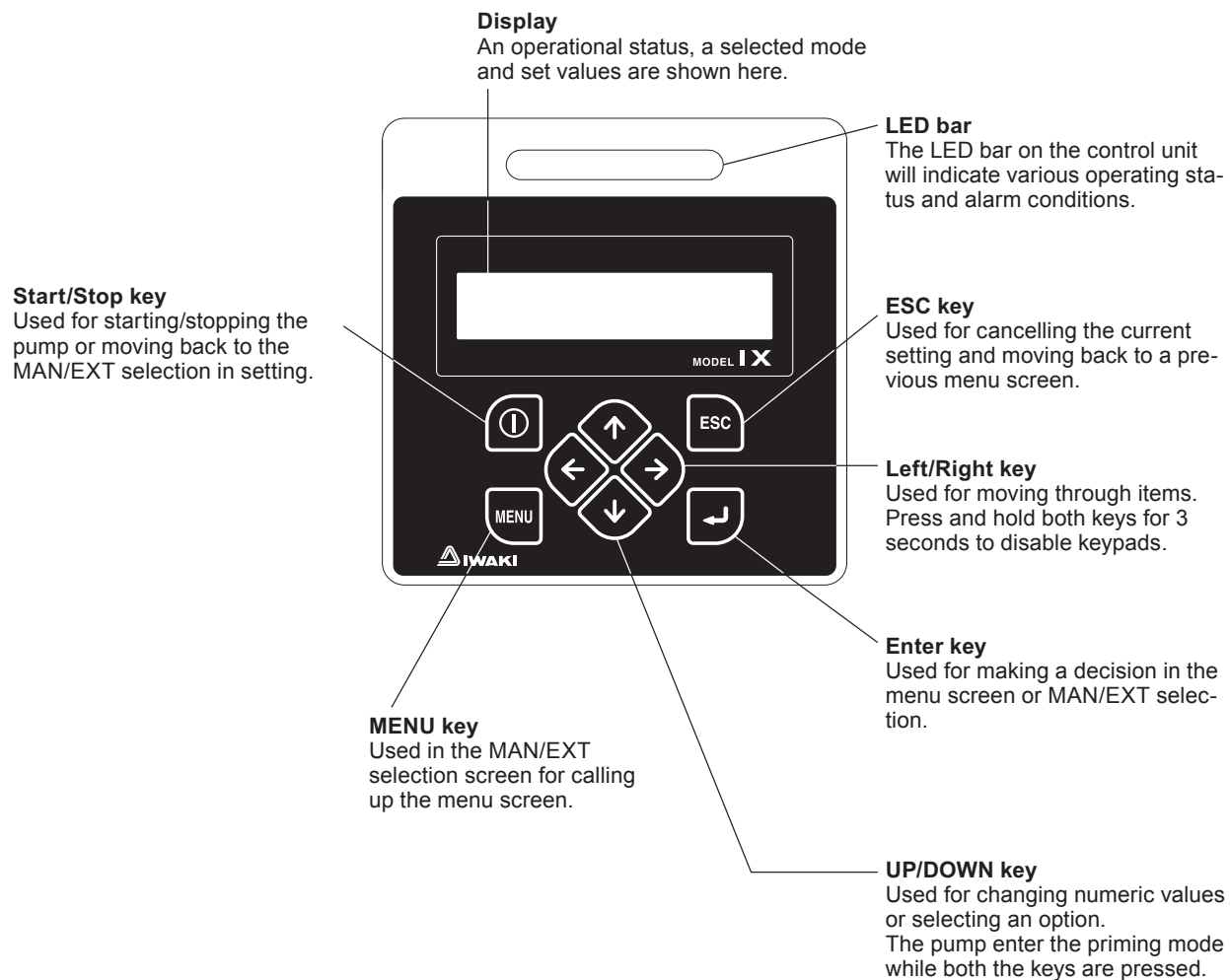

■ Basic displays & Pump states

	Display	Red LED bar	Green LED bar	Orange LED bar	White/Purple LED bar
Operation	PUMP On (Manual) 45.0 L/H	—	Flows in MAN mode operation.	—	—
	PUMP On (ANA.P) 45.0 L/H	—	Lights (waits) or Flows (runs) in EXT mode (Analog control).	—	—
	AUX IN OVERRIDE! 45.0 L/H	—	Flows (runs) in AUX operation.	—	—
	PRIMING OVERRIDE 45.0 L/H	—	Flows in priming mode.	—	—
	Pre-Stop (MAN) 45.0 L/H	—	—	Lights (waits) or Flows (runs) when Pre-STOP function is active.	—
Stop	Standby (Manual) 45.0 L/H	—	—	—	A white lights (pump waits) in the MAN mode.
	Standby (EXT) Analog Preset	—	—	—	A white lights (pump waits) in the EXT mode.
	SELECT OPERATION MAN ← → EXT (ANA.P)	—	—	—	A white lights (pump waits) in the MAN/EXT selection.
	MAIN MENU: ← Program EXT →	—	—	—	A white lights (pump waits) in a main menu screen.
	MOTOR OVERLOAD! S/S Key = Clear	Blinks when the pressure overload protection is active.	—	—	—
	LEAK DETECTED! S/S Key = Clear	Blinks when the diaphragm is broken.	—	—	—
	DRIVE ERROR! S/S Key = Clear	Blinks when a rotation control is upset.	—	—	—
	STOPPED (Manual) -----	—	—	—	A purple lights.
INTERLOCKED (MAN) -----	Lights (waits) when the pump is interlocked.	—	—	—	

*The white LED bar lights when the pump is turned ON.

Identification codes

Each code represents the following information.

Pump

IX - B 007 TC N - U

a b c d e f g

a. Series name

IX

b. Drive unit

B

c. Pump unit (Max flow)

007 : 7.5 [L/H] 015 : 15 [L/H] 030 : 30 [L/H] 045 : 45 [L/H]

d. Wet end materials

Code	TC	TE	S6
Pump head	PVDF		SUS316
Ball valve	CE		SUS316
Valve seat	FKM	EPDM	SUS316
O ring	FKM	EPDM	-
Valve gasket	-		PTFE
Diaphragm	PTFE + PFA		

Material code

PVDF : Polyvinylidene difluoride CE : Alumina ceramics
 FKM : Fluorine-contained rubber PTFE : Polytetrafluoroethylene
 EPDM : Ethylene-propylene rubber PFA : Perfluoroalkoxy alkanes
 SUS316 : Austenite stainless steel

e. Connection

R : R thread N : NPT thread G : G thread (TC/TE) F : Flange (TC/TE)
 T : 1/4"x3/8" tube (IX-B 007/015 TC/TE) or 3/8"x1/2" tube (IX-B 030/045 TC/TE) FA : ANSI Flange (S6)

f. Power plug

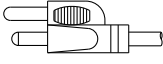
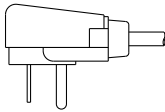
Code	U	U2
Plug shape		
	115V (1950mm length)	230V (1950mm length)

g. Special version

No code : Standard models
 : Customized models will be coded.

Installation

***This section describes the installation of the pump, piping and wiring.
Read through this section before work.***

! Points to be observed

Observe the following points when installing the pump.

- Risk of electrical shock. Be sure to turn off power to stop the pump and related devices before service is performed.
- If you notice any abnormal or dangerous conditions, suspend operation immediately and inspect/solve problems.
- Do not place explosive or flammable material near the pump.
- Use of a damaged pump could lead to an electric shock or death.

Pump mounting

Select an installation location and mount the pump.

Necessary tools

- Four M6 bolts (pump mounting)
- Adjustable wrench or spanner

Floor mounting

- 1** Select a suitable place.
Always select a flat floor free of vibrations. See page 10 for detail.

- 2** Anchor the pump by four M6 bolts.
Be sure to fix the pump at four points.

NOTE
Select a level location, or the flow may reduce.

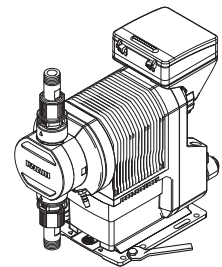

Wall mounting

■ Mounting

1 Select a suitable place.

Select a rigid vertical wall on which the pump is mounted. Use the anchorage points guide (see page 87) and drill four holes to have your M6 anchor nuts.

2 Remove the six (6) M4 screws and the detachable pump base.

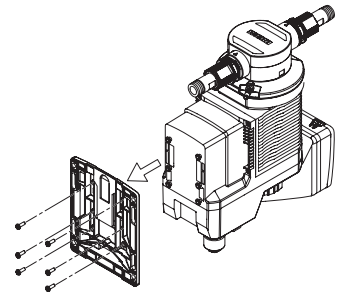

3 Use four (4) M6 anchor bolts and fix the pump base onto the vertical wall.

The pump base have a mounting direction, the push mark upward.

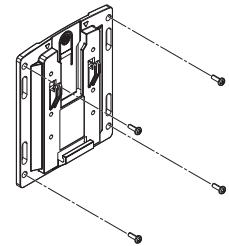

4 Hang the pump onto the pump base.

The inverted triangles on the base shows the location where the pump is to be hooked.

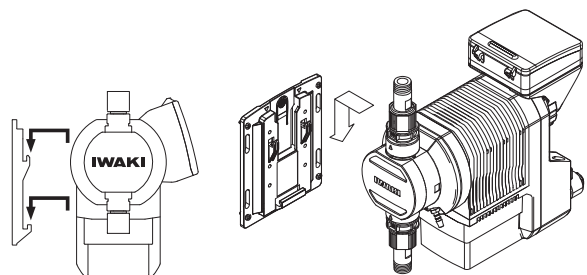

5 Slide in the attached mounting adapter to the upper side of the base.

Mounting adapter

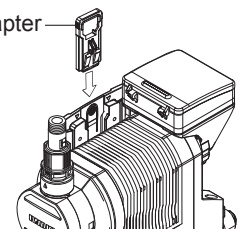

6 Check the pump is held vertical and won't move.

Make sure the pump is held tight again. Do not drop or damage.

■ Demounting

- 1** Press the push mark and remove the mounting adapter from the base.

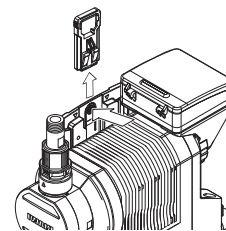

- 2** Push the pump toward to the wall to unhook/demount the pump from the base.

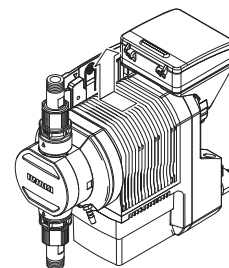

Console positioning

The 4-position control unit and 5-position rear case can be adjusted to the best position.

Necessary tools

- Phillips screwdriver

■ Control unit

- 1 Turn the control unit to the best position.
It can turn clockwise and "sit" at the 3 o'clock position or counter-clockwise at the 9 and 6 o'clock positions.

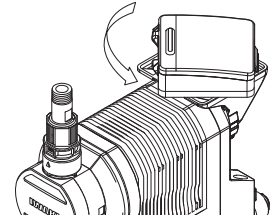

■ Rear case

- 1 Remove the cap and loosen the screw (a few turns).

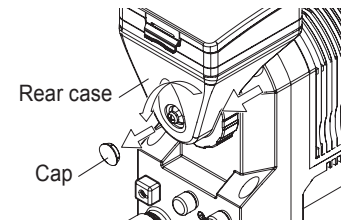

- 2 Adjust the rear case to the best direction.
It can turn clockwise/counter-clockwise and "sit" at the 35° and the 70° positions from the top position.

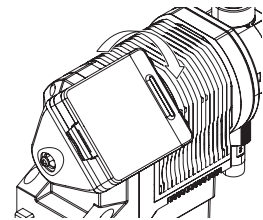

- 3 Tighten the rear case with the screw and remount the cap.
Make sure it is fasten tight and won't move.

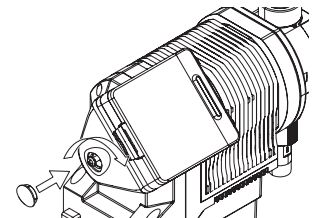

- 4 Turn the control unit to the upright position as necessary.

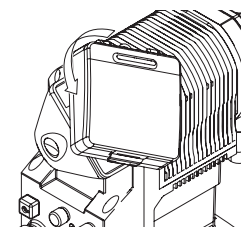

Plumbing

■ Piping layout

Flooded suction application

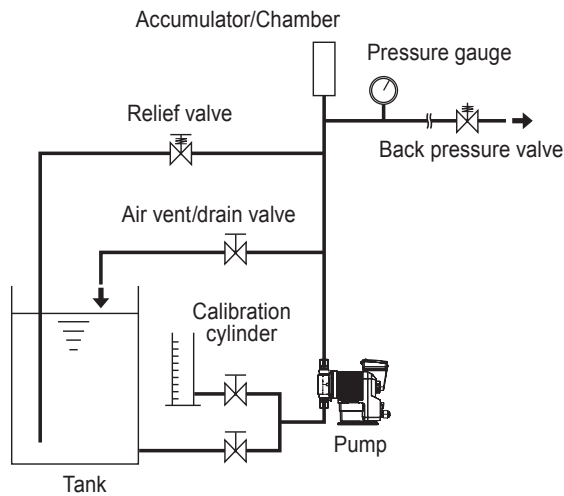

Suction lift application

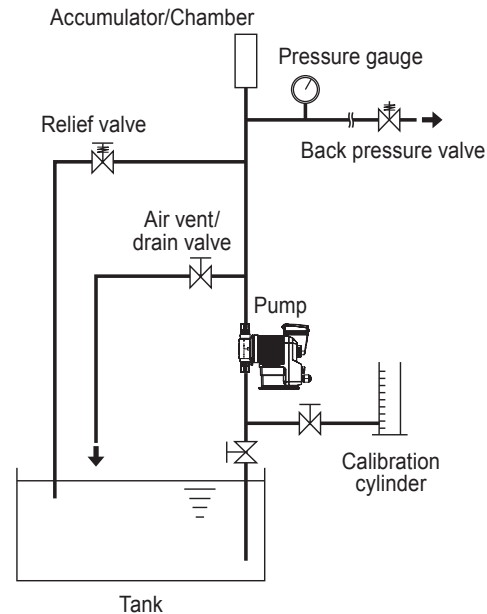

NOTE

- The suction line I.D. should be equal to or wider than the I.D. of the pump.
- When handling liquids that generate gas bubbles (sodium hypochlorite or hydrazine solution), install the pump in a cool and dark place. Flooded suction installation is strongly recommended.

Installation

Tube connection

- Pass a tube into the fitting nut and stopper and then slide it down to the adapter as far as it will go.
- Put the tube end (adapter) in the fitting. Then hand tighten the fitting nut.
- Retighten the fitting nut by turning it further 180 degrees with an adjustable wrench or spanner (crush tube mount).

- *Do not use excessive force to the plastic fitting nut.
- *In your try to remove the connection, the adapter may be stuck in the crushed tube and the stopper. Try not to damage the taper of the adapter that is crushing the tube against the stopper. If it has been damaged, contact us for the new adapter/stopper.
- *Do not reuse the same tube end for the crush sealing. Cut it off for ensuring the new seal is established.

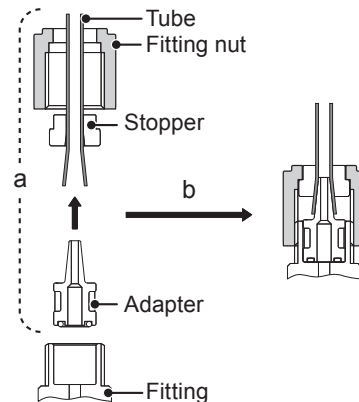

Drain port (Vent hole)

Leaked liquid drains off through the drain port if the diaphragm is ruptured accidentally. Use a chemically-resistant tube to the port and a drain tank to safely collect the liquid.

NOTE

- Do not plug the drain port. The port functions as a vent hole to keep the pressure behind the diaphragm back atmospheric.
- Do not immerse the end of a drain tube in drained liquid, or the liquid may be pumped up into the compartment behind the diaphragm back.
- Liquid in the drain tank is the sign of the damaged diaphragm. Immediate inspection or repair is necessary. Do not leave this condition as it is. Fumes or vapors from certain solutions may move up into the pump via the drain tube and attack its inside.

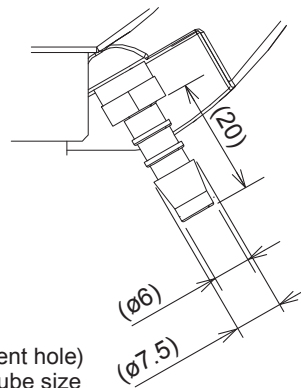
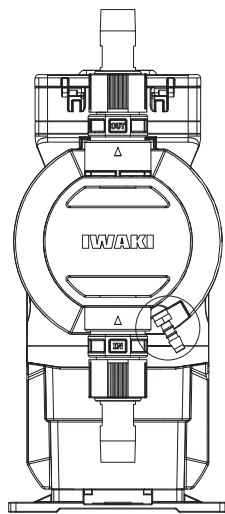

Drain port (vent hole)
*Applicable tube size
Inner diameter: 6mm
Outer diameter: 12mm or below

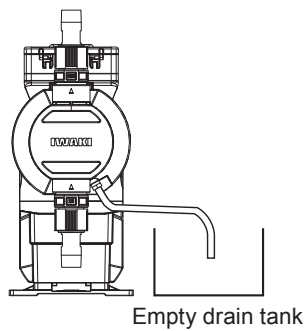

Do not locate the drain tube end below the liquid level.



Do not take in fumes from corrosive chemicals such as sodium hypochlorite.

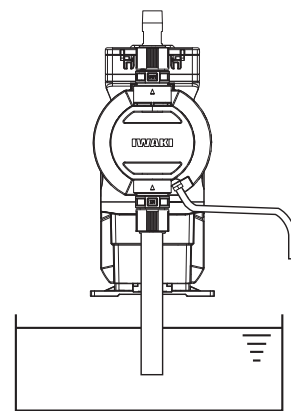
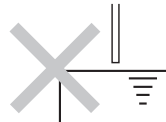

Noncorrosive chemicals in a supply tank. The drain tube end must stay above the liquid level.

Wiring

Wiring for power voltage, earthing and external signals.

! Points to be observed

Observe the following points during wiring work.

- Electrical work should be performed by a qualified electrician. Always observe applicable codes or regulations.
- Do not apply power other than that specified on the nameplate. Otherwise, failure or fire may result.
- Do not perform wiring work while electric power is on. Otherwise, an electrical shock or a short circuit may result. Be sure to turn off the power before wiring work.
- Be careful for electric power not to be turned on during work.
- Replacement of a power cable should be conducted by a manufacturer, his agency or a skilled person. Otherwise, an accident may result.

End terminals

See the following diagram for detail.

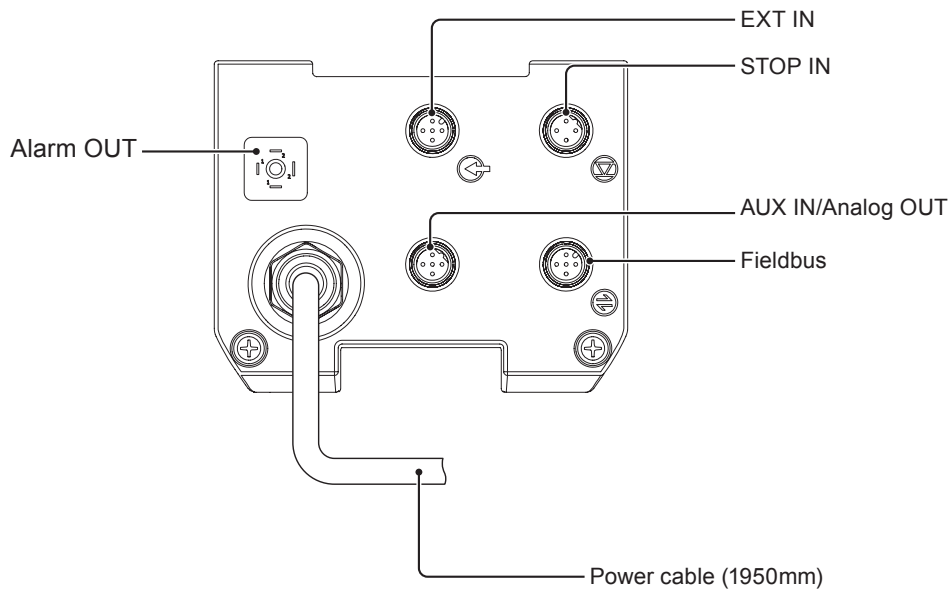

Power voltage/Earthing

Points to be checked

- Check that power voltage is turned off.

1 Insert the plug all the way seated in a socket.

NOTE

- Do not share a power source with a high power device which may generate a surge voltage. Otherwise an electronic circuit may fail. The conductive noise caused by an inverter also affects the circuit.
- Energize the pump with a power voltage via a mechanical relay or switch. Do not fluctuate the voltage, or CPU may malfunction. See page 35 for the precautions for ON-OFF control by a mechanical relay.

Apply power sharply

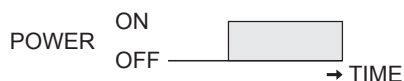

Do not apply gradually



Surge voltage

The electronic circuit in the control unit may fail due to a surge voltage. Do not place the pump close to a high power device of 200V or more which may generate a large surge voltage. Otherwise, take any of the following measures.

- Install a surge absorption element (such as a varistor with capacity of 2000A or more) via power cable or,

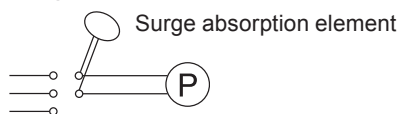

Recommended varistors:

Panasonic ERZV14D431

KOA NVD14UCD430

See manufacturer's catalogues for detail.

- A noise cut transformer via the power cable.

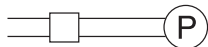

Noise cut transformer

Precautions for ON-OFF control by a mechanical relay

The control unit is equipped with a CPU. To ensure the CPU to work properly, always start/stop the pump by the STOP signal for ON-OFF control. Try not to turn on and off the main power. Otherwise, observe the following points:

- Ensure the minimum OFF time of 10 minutes.
- The contact capacity of a mechanical relay should be 5A or more. Or a contact point may break.
- If the contact capacity of a mechanical relay is 5A, the maximum allowable number of times the power is turned ON/OFF is 150,000. The contact capacity should be 10A or more when the actual number of times is over 150,000 or when sharing a power source with a large capacity equipment which may cause a surge voltage and damage a contact point.
- Use a solid state relay (SSR) as necessary (such as the OMRON G3F). See manufacturer's catalogues for detail.

Signal wire connection

Points to be checked

- Check that power voltage is turned off.

Use our optional connector cables below or purchase DIN 4- and 5-pin female connector cables when using signal input and output.

Optional 5m DIN connector cables for:

The EXT input signal (or Binder 99-0436-10-05 Series 713)

The STOP input signal (or Binder 99-0430-15-04 Series 715)

The AUX input/Analog output signals

The Alarm output signal (or Hirschmann GDS307)

NOTE

- Do not lay on these signal cables in parallel with a power cable. Otherwise the electromagnetic induction noise is generated and malfunction or failure may result.
- The following products are the recommended SSRs (Solid State Relays) for signal input. Any other SSRs might cause malfunction. See manufacturer's information for details on these SSRs.
 - OMRON G3FD-102S or G3FD-102SN
 - OMRON G3TA-IDZR02S or G3TA-IDZR02SM
- When using a mechanical relay for signal input, its minimum application load should be 5mA or below.
- Insert the DIN 4- or 5-pin female connector as far as it will go and then tighten the skirt to make a secure connection.

*Use either a no-voltage contact or an open collector for the EXT input signal.

■ EXT IN

To make pulse-, batch-, interval batch- and analog-control operation or to activate interlock function, connect signal wires to the EXT terminals via the DIN 5-pin connection.

When using an open collector:

Pay attention to polarity. The pulse (1) pin and the interlock (2) pin are plus (+), and the COM (4) pin is minus (-).

When using analog control:

Pay attention to polarity. The analog (3) pin is plus (+), and the COM (4) pin is minus (-). Internal resistance is 200Ω.

When using a no-voltage contact:

Use a mechanical relay designed for an electronic circuit. Its minimum application load should be 5mA or less.

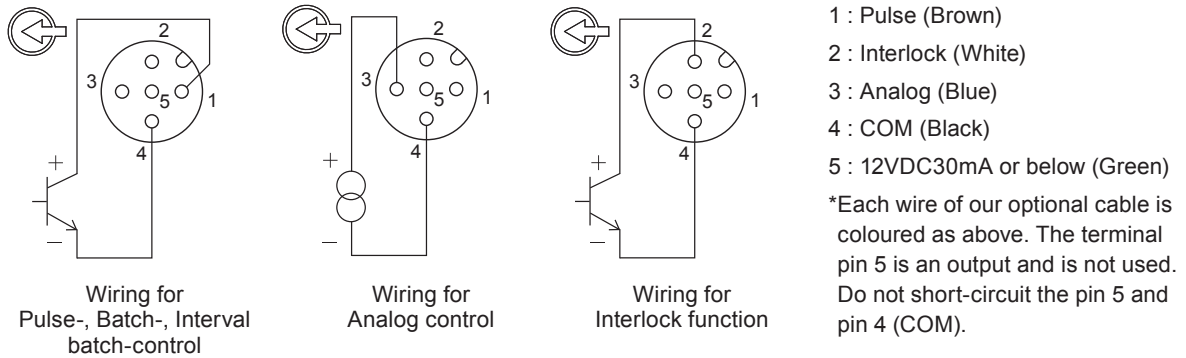

■ STOP IN

To activate STOP function, connect signal wires to the STOP terminal via the DIN 4-pin connection.

When using an open collector:

Pay attention to polarity. The STOP (1) pin and the Pre-STOP (2) pin are plus (+), and the COMs (3 and 4) pins are minus (-).

When using a no-voltage contact:

Use a mechanical relay designed for an electronic circuit. Its minimum application load should be 5mA or less.

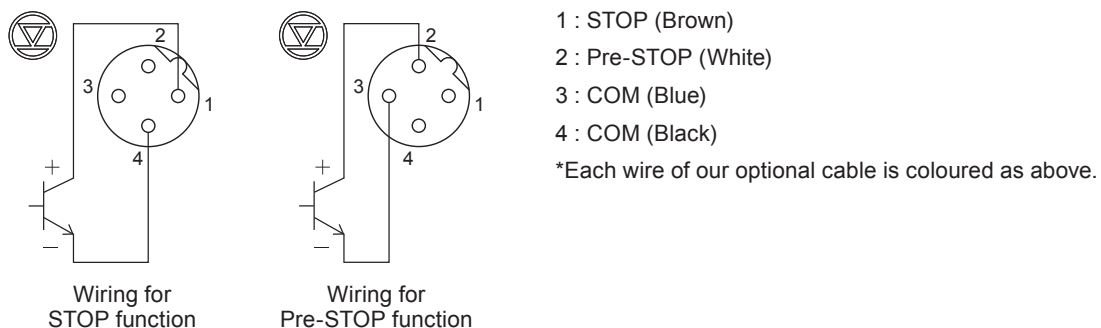

NOTE

Our optional cable has 5 wires. Cut off a green wire to use it with the DIN 4-pin connector.

■ AUX IN/Analog OUT

To activate the AUX function or to use the analog output, connect signal wires to the AUX terminal or the 4-20mA output terminal via the DIN 5-pin connection.

When using an open collector (for AUX IN):

Pay attention to polarity. The AUX (3) pin is plus (+), and the COM (4) pin is minus (-).

When using a no-voltage contact (for AUX IN):

Use a mechanical relay designed for an electronic circuit. Its minimum application load should be 5mA or less.

When using analog output:

Pay attention to polarity. The 4-20mA (1) pin is minus (-), and the 4-20mA (5) pin is plus (+). The max load resistance is 300Ω.

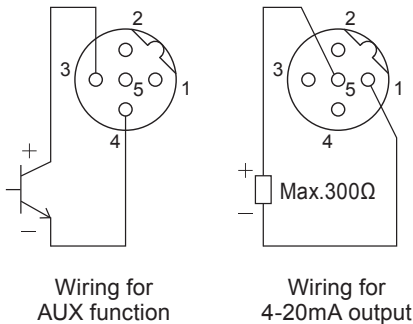

- 1 : 4-20mA (Brown)
- 2 : N.C. (White)
- 3 : AUX (Blue)
- 4 : COM (Black)
- 5 : 4-20mA (Green)

*Each wire of our optional cable is coloured as above
 *Do not use the N.C. pin which is used for maintenance service.

■ Alarm OUT (DIN connector)

To transmit the signal to an external device, connect signal wires to the OUT terminal via the DIN 4-pin connection.

Alarm OUT 1 (OUT 1) <Mechanical relay>: Enable or disable the alarm outputs of batch completion, STOP, Pre-STOP, interlock, motor overload (/drive error) and leak detection individually.

*The leak detection option only is enabled at the factory default setting.

Alarm OUT 2 (OUT 2) <PhotoMOS relay>: Enable or disable the alarm outputs of the volume proportional pulse, batch completion, STOP, Pre-STOP, interlock, motor overload (/drive error) and leak detection individually.

*The interlock option only is enabled at the factory default setting.

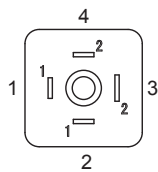

- 1 : Alarm OUT 1 (White)
- 2 : Alarm OUT 1 (Brown)
- 3 : Alarm OUT 2 (Black)
- 4 : Alarm OUT 2 (Blue)

*Each wire of our optional cable is coloured as above.

Mounting direction of the output signal cable

Mount the DIN square connector cable in the following direction and secure it with a M3 screw.

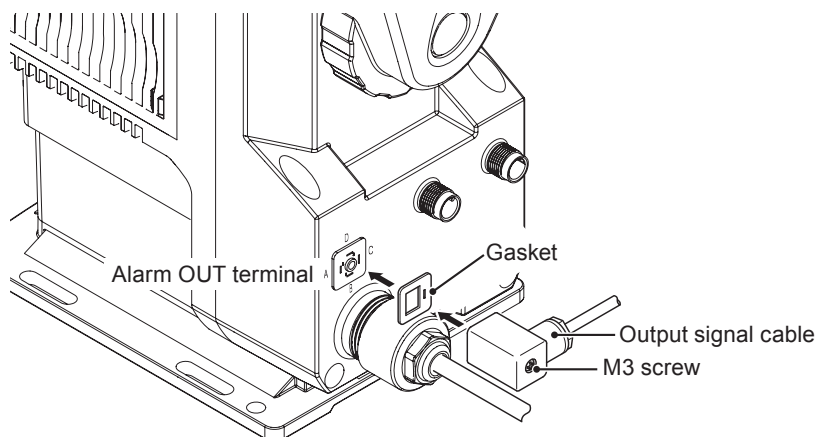

Operation

This section describes pump operation and setting. Run the pump after plumbing and wiring are completed.

Before operation

First check piping and wiring are correct. And then make commissioning before starting operation.

Points to be checked

Before operation, check if:

- Liquid level in a supply tank is enough.
- Piping is securely connected and is free from leakage and clogging.
- Discharge/suction valves are opened.
- Power voltage range is correct.
- Electrical wiring is correct and is free from the risk of short circuit and electrical leakage.

Retightening of pump head fixing bolts

Important

The pump head fixing bolts may loosen when plastic parts creep due to temperature change in storage or in transit, and this can lead to leakage. Be sure to retighten the bolts evenly to the specified tightening torque below in diagonal order before starting operation.

Tightening torque

Model code	Torque	Bolts	Number of bolts
IX-B007/-B015/-B030/-B045	3 N•m	M5 hexagon head bolt	4

*Tighten fixing bolts once every three months.

Commissioning

Always make commissioning when first mounting the pump in your system or resuming operation after a long period of stoppage.

- 1 Open an air vent and a suction line.
Do not open a calibration line if any.

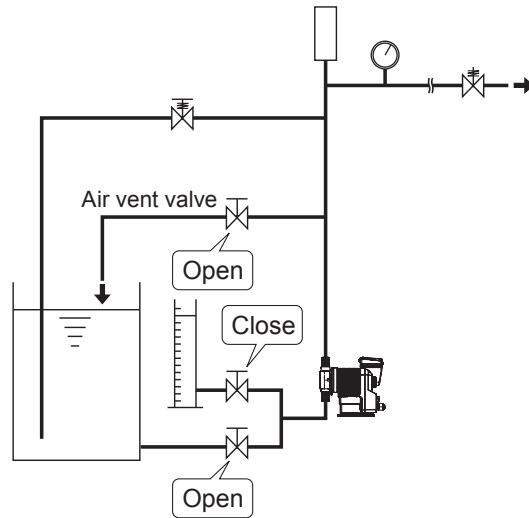

- 2 Supply the rated power voltage to the pump.
- 3 Start the pump at a low flow rate and gradually increase it to a target rate.
Continue operation for 10 minutes and check the pump and plumbing for any abnormality.
- 4 Close an air vent line to introduce liquid to a main line.

Before a long period of stoppage (One month or more)

Clean wet ends and the inside of piping.

- Run the pump with clean water for about 30 minutes to rinse chemicals off.

Before unplugging the pump

- Always stop the pump by key operation and wait for three seconds before unplugging the pump. Or the last key operation may not be put in memory, and the pump unintentionally starts to run as powered on, discharging liquid.

When the pump does not transfer liquid at resuming operation.

- Clean the valve sets and remove foreign matters.
- If air is in the pump head, expel air through the above commissioning procedure.

Perform a calibration

Periodically make calibration to monitor an accurate flow through control display. The pump is calibrated by pumping clean water at the maximum operating pressure before shipping (in the absence of a designation by a user), however, make calibration again in an actual operating condition as necessary. Follow the calibration process on the next page.

NOTE

The flow rate shown on the screen is a calculated value based on calibration and is not an actual flow rate.

Calibration is made to determine liquid volume per shot. Arrange your piping system according to the guide below to ensure the calibration is made correctly.

Suggested piping layout

Use a calibration cylinder connected to a suction line.

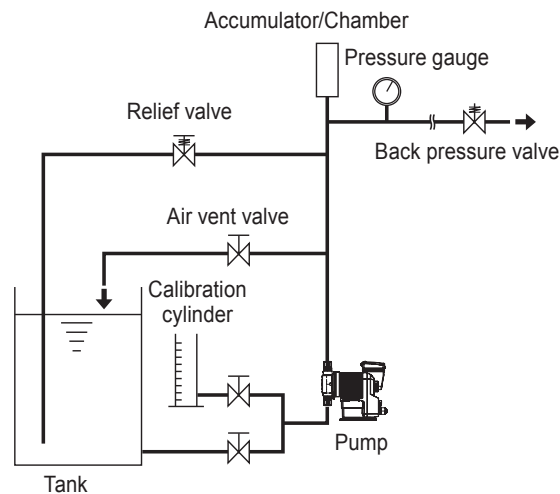

Bad example

Do not immerse a calibration tube into liquid in a calibration cylinder. Tube volume is added to the liquid volume to be measured, and calibration will be upset.

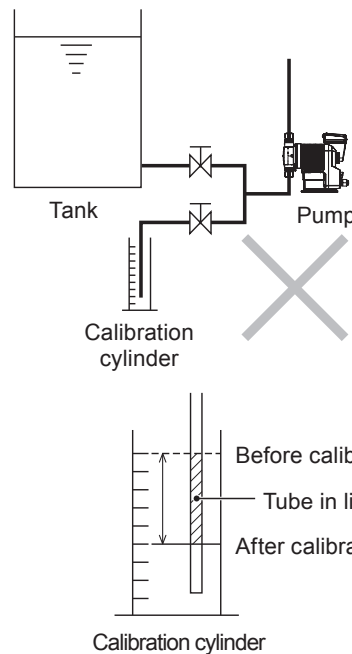

Calibration process

Obtain accurate flow volume per shot (e.g. IX-B007: 0.6ml/shot, IX-B015: 1.3ml/shot, IX-B030: 2.5ml/shot, IX-B045: 3.8ml/shot) by dividing the delivered liquid volume by the number of strokes.

1 Fill a calibration cylinder with liquid.

Open a calibration line to lead liquid from a supply tank to a calibration cylinder. And then close the suction line and measure liquid volume in the cylinder.

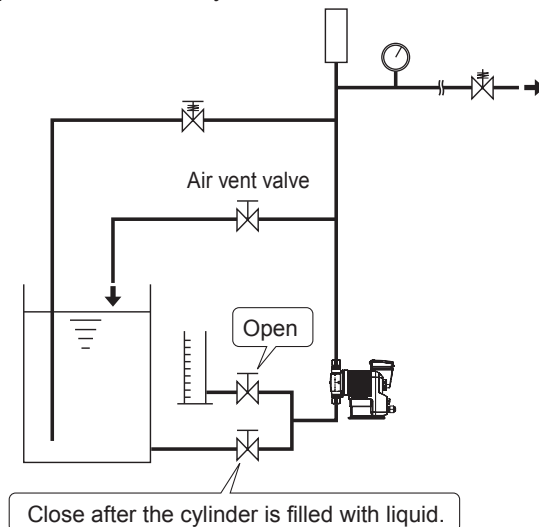

2 Supply the rated power voltage to the pump and set a flow rate in the manual mode.

See page 13 for detail.

NOTE

The calibration accuracy won't change at any flow rate. The higher the flow rate is, the shorter time it takes, and vice versa.

3 Select the calibration mode through the menu screen.

See page 44 for detail.

4 Calibration operation setting

Set a waiting time and the number of strokes. The number of strokes should be determined depending on liquid volume in the calibration cylinder.

Waiting time to start calibration operation : 10(default)-999s

Number of strokes : 60(default)-120ST

Wait Time: 10s
Strokes: 60ST

Use UP and DOWN keys to set a waiting time.



Wait Time: 20s
Strokes: 60ST

Use UP and DOWN keys to set the number of strokes.

5 Start calibration operation.

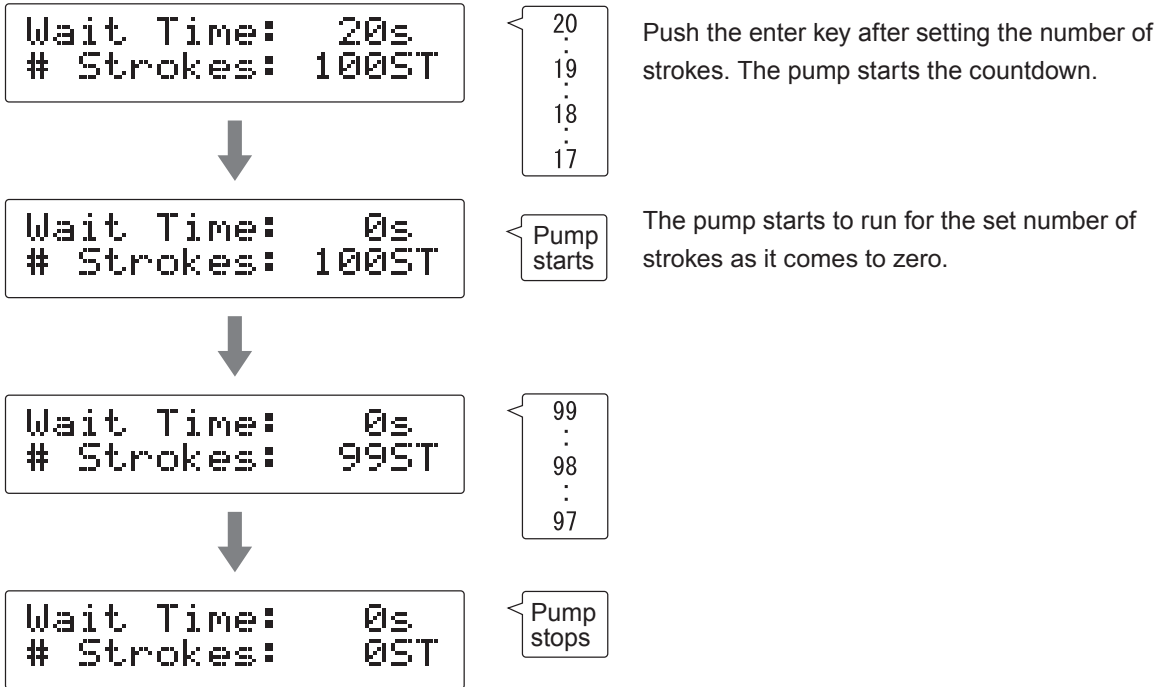

6 Measure liquid volume in the calibration cylinder again.

7 Enter how much liquid has reduced.

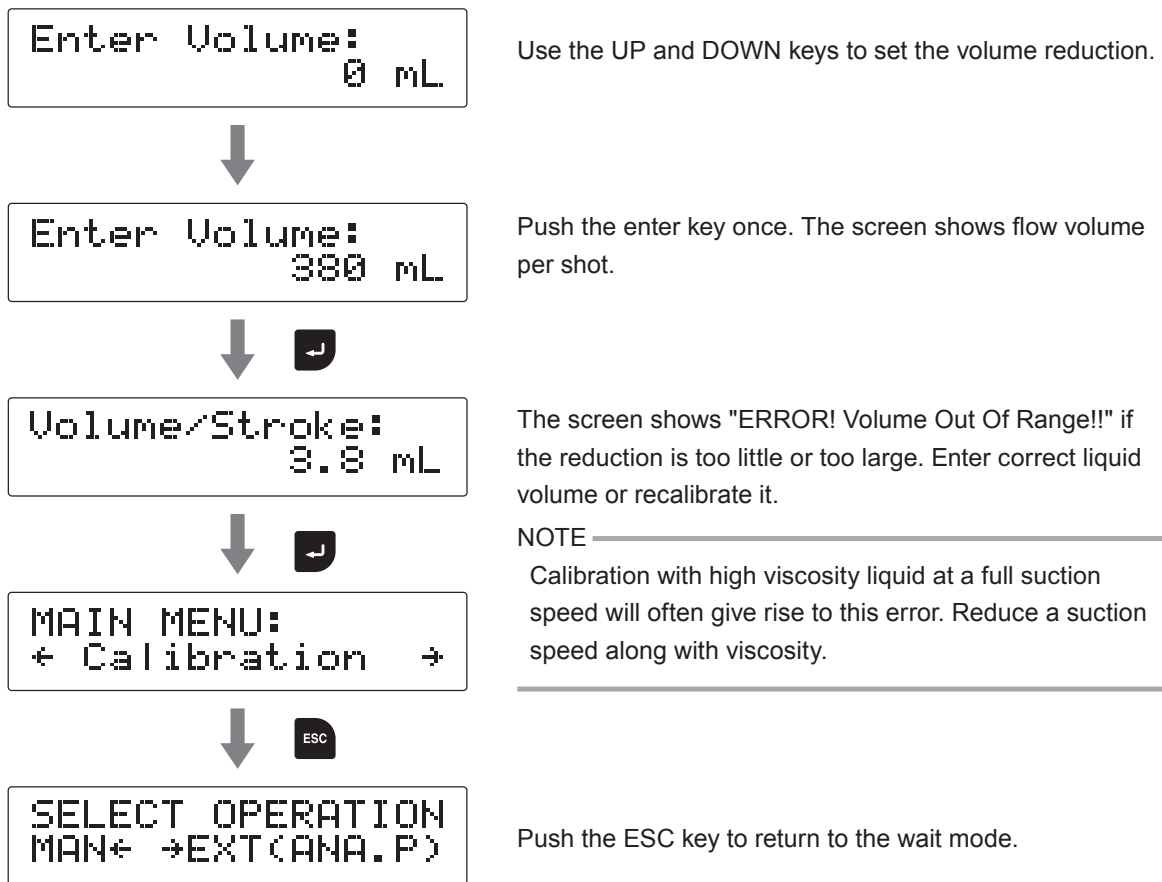

Operation setting

The setting is made with the controller. The pump behaviour differs with each control mode.

Menu	Control mode/Function	Parameter	Factory default	
Mode selection	-	MAN/EXT	MAN	
External controls	Analog preset control	4-20mA/ 0-20mA/ 20-4mA/ 20-0mA	4-20mA	
	Analog variable control	SP1 current	0.0mA-20.0mA	4.0mA
			0mL/H, 7.50mL/H-7.50L/H (B007)	0mL/H
		SP1 flow rate	0mL/H, 15.0mL/H-15.0L/H (B015)	0mL/H
			0mL/H, 30.0mL/H-30.0L/H (B030)	0mL/H
			0mL/H, 45.0mL/H-45.0L/H (B045)	0mL/H
			0mL/H, 45.0mL/H-45.0L/H (B045)	0mL/H
		SP2 current	0.0mA-20.0mA	20.0mA
			0mL/H, 7.50mL/H-7.50L/H (B007)	7.50L/H
	0mL/H, 15.0mL/H-15.0L/H (B015)		15.0L/H	
	0mL/H, 30.0mL/H-30.0L/H (B030)		30.0L/H	
	SP2 flow rate	0mL/H, 45.0mL/H-45.0L/H (B045)	45.0L/H	
		0.000625mL/PLS-15.000000mL/PLS (B007)	0.006250mL/PLS	
		0.001250mL/PLS-30.000000mL/PLS (B015)	0.012500mL/PLS	
		0.002500mL/PLS-60.000000mL/PLS (B030)	0.025000mL/PLS	
	Pulse control*	0.0037500mL/PLS-90.000000mL/PLS (B045)	0.037500mL/PLS	
		0.625mL/PLS-15.000L/PLS (B007)	6.2500mL/PLS	
		1.250mL/PLS-30.000L/PLS (B015)	12.500mL/PLS	
2.500mL/PLS-60.000L/PLS (B030)		25.000mL/PLS		
Batch control*	3.750mL/PLS-90.000L/PLS (B045)	37.500mL/PLS		
	0-9 days/ 0-23 hr/ 1-59 min	0D: 0H: 1M		
	0.625mL - 15.000L (B007)	6.2500mL		
	1.250mL - 30.000L (B015)	12.500mL		
Interval batch control†	2.500mL - 60.000L (B030)	25.000mL		
	3.750mL - 90.000L (B045)	37.500mL		
	Profibus control	Address: 1-126	50	
	Inputs	STOP	Closed=Pump OFF, Closed=Pump ON	Closed=Pump OFF
PreSTOP		Closed=Pump OFF, Closed=Pump ON	Closed=Pump OFF	
Interlock		Closed=Pump OFF, Closed=Pump ON	Closed=Pump OFF	
Leak detection		Enable, Disable	Enable	
Alarm	OUT1	Batch Complete, Stop, Pre-Stop, Interlock, Leak Detection, Motor Overload, Drive Error	Leak Detection: Enable Other alarms: Disable	
	OUT2	Volume Prop. PLS, Batch Complete, Stop, Pre-Stop, Interlock, Leak Detection, Motor Overload, Drive Error	Interlock: Enable Other alarms: Disable	
Analog output	SP1 current	0.0mA-20.0mA	4.0mA	
		0.00mL/H, 7.50mL/H-7.50L/H (B007)	0.00mL/H	
	SP1 flow rate	0.00mL/H, 15.0mL/H-15.0L/H (B015)	0.00mL/H	
		0.00mL/H, 30.0mL/H-30.0L/H (B030)	0.00mL/H	
		0.00mL/H, 45.0mL/H-45.0L/H (B045)	0.00mL/H	
		0.00mL/H, 45.0mL/H-45.0L/H (B045)	0.00mL/H	
	SP2 current	0.0mA-20.0mA	20.0mA	
		0.00mL/H, 7.50mL/H-7.50L/H (B007)	7.50L/H	
0.00mL/H, 15.0mL/H-15.0L/H (B015)		15.0L/H		
0.00mL/H, 30.0mL/H-30.0L/H (B030)		30.0L/H		
SP2 flow rate	0.00mL/H, 45.0mL/H-45.0L/H (B045)	45.0L/H		
	Suction speed	100%/ 75%/ 50%/ 25%	100%	
		7.50mL/H-7.50L/H (B007)	7.50L/H	
		15.0mL/H-15.0L/H (B015)	15.0L/H	
30.0mL/H-30.0L/H (B030)		30.0L/H		
Max flow rate	45.0mL/H-45.0L/H (B045)	45.0L/H		
	7.50mL/H-7.50L/H (B007)	7.50L/H		
	15.0mL/H-15.0L/H (B015)	15.0L/H		
	30.0mL/H-30.0L/H (B030)	30.0L/H		
AUX speed	45.0mL/H-45.0L/H (B045)	45.0L/H		
	Diaphragm position	MAX OUT Pos./ MAX IN Pos.	MAX OUT Pos.	
	Buffer	Enable, Disable	Disable	
	Anti-Chattering	1 msec, 2 msec, 5 msec	5 msec	
Output logic (OUT1)	Normally Open / Normally Close	Normally Open		
Output logic (OUT2)	Normally Open / Normally Close	Normally Open		
Unit	Litter, US Gallon	Litter		
Keypad lock	00000-99999	00000		
Language	English, Dutch, French, Danish, Spanish, German	English		

*For these control modes, the calibrated flow volume per shot is applied to the minimum settable flow volume.

Setting flow chart

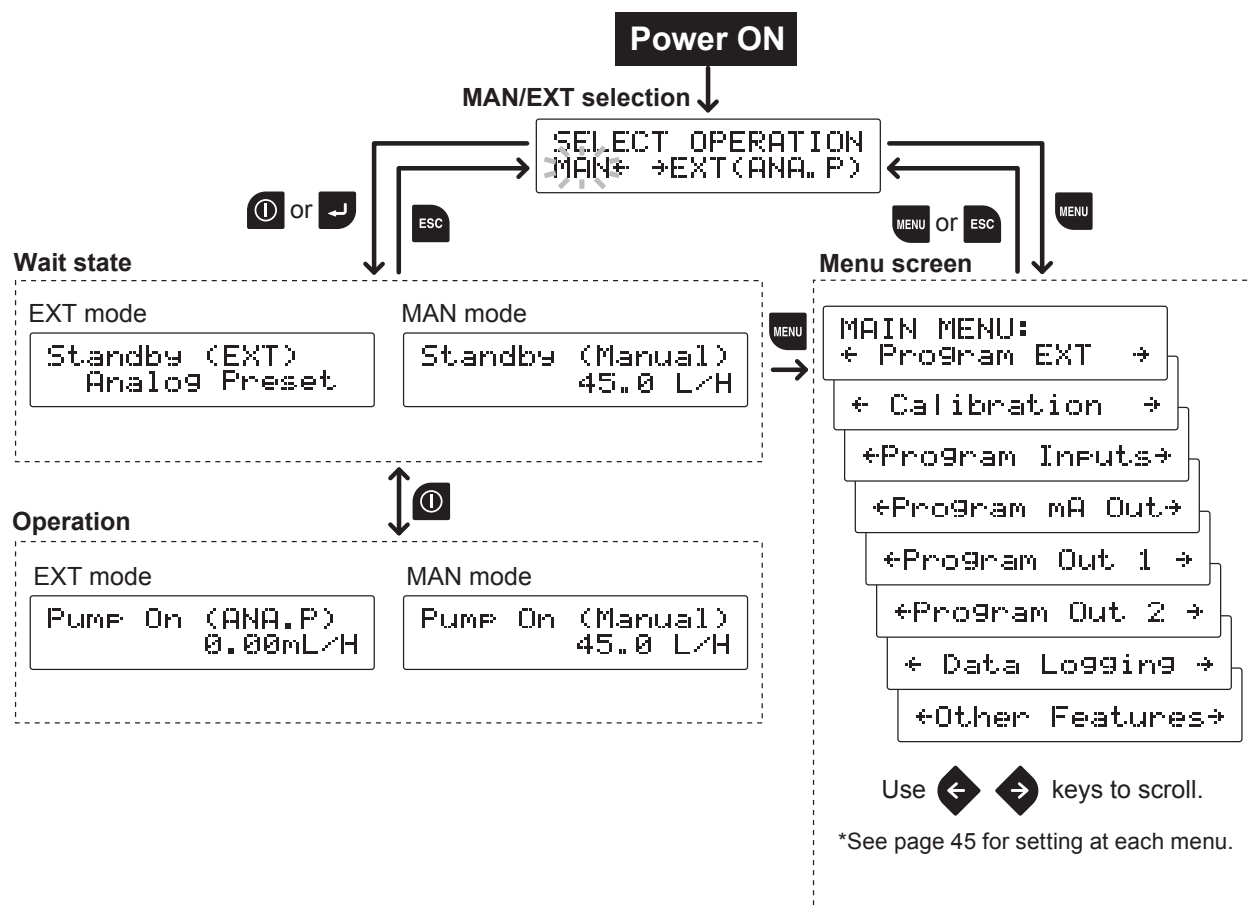

*To revert back to the factory default setting with the pump calibrated, turn on power while pressing the ESC key.

Menu screen

Push the MENU key in the MAN/EXT selection mode and call up the menu screen. Use the right and left keys to scroll through each menu item and then push the enter key to make a selection. Pushing the MENU key again or ESC key in the menu screen, the previous mode will be recalled.

```
MAIN MENU:
← Program EXT →
```

EXT mode selection

The pump can run in four different operating modes of Analog, Pulse, Batch, Interval Batch, and profibus for the external signal. See page 14-18 and 46 for detail.

```
MAIN MENU:
← Calibration →
```

Calibration

Calibrate the pump to obtain a correct flow rate on the screen. See page 41 and 48.

```
MAIN MENU:
←Program Inputs→
```

Signal input setting

Set the inputs of the STOP, Pre-STOP, interlock functions, and diaphragm rupture detection. See page 19, 20, 49 and 50.

```
MAIN MENU:
←Program mA Out→
```

Analog output setting

Set the output current at SP1 and 2 flow rates to configure the analog signal output behaviour. See page 21 and 50.

```
MAIN MENU:
←Program Out 1 →
```

Alarm output setting (OUT 1)

Enable or disable the output of the batch completion, STOP, Pre-STOP, interlock, diaphragm rupture detection, overload/failed speed detection, and/or drive error detection functions. See page 21 and 51.

```
MAIN MENU:
←Program Out 2 →
```

Alarm output setting (OUT 2)

Enable or disable the output of the batch completion, STOP, Pre-STOP, interlock, diaphragm rupture detection, overload/failed speed detection, drive error detection, and/or volume proportional pulse functions. See page 21 and 51.

```
MAIN MENU:
← Data Logging →
```

Data logging

The pump can display operating time, total flow volume, power-on time, the number of ON/OFF and software version. See page 54.

```
MAIN MENU:
←Other Features→
```

Setting of other functions

Set a suction speed, a max flow rate, an AUX speed, a diaphragm position, an anti-chattering time, butter ON/OFF, output logics, a flow rate unit and your language or so. See page 22, 55, 56 and 57.

■ EXT mode selection

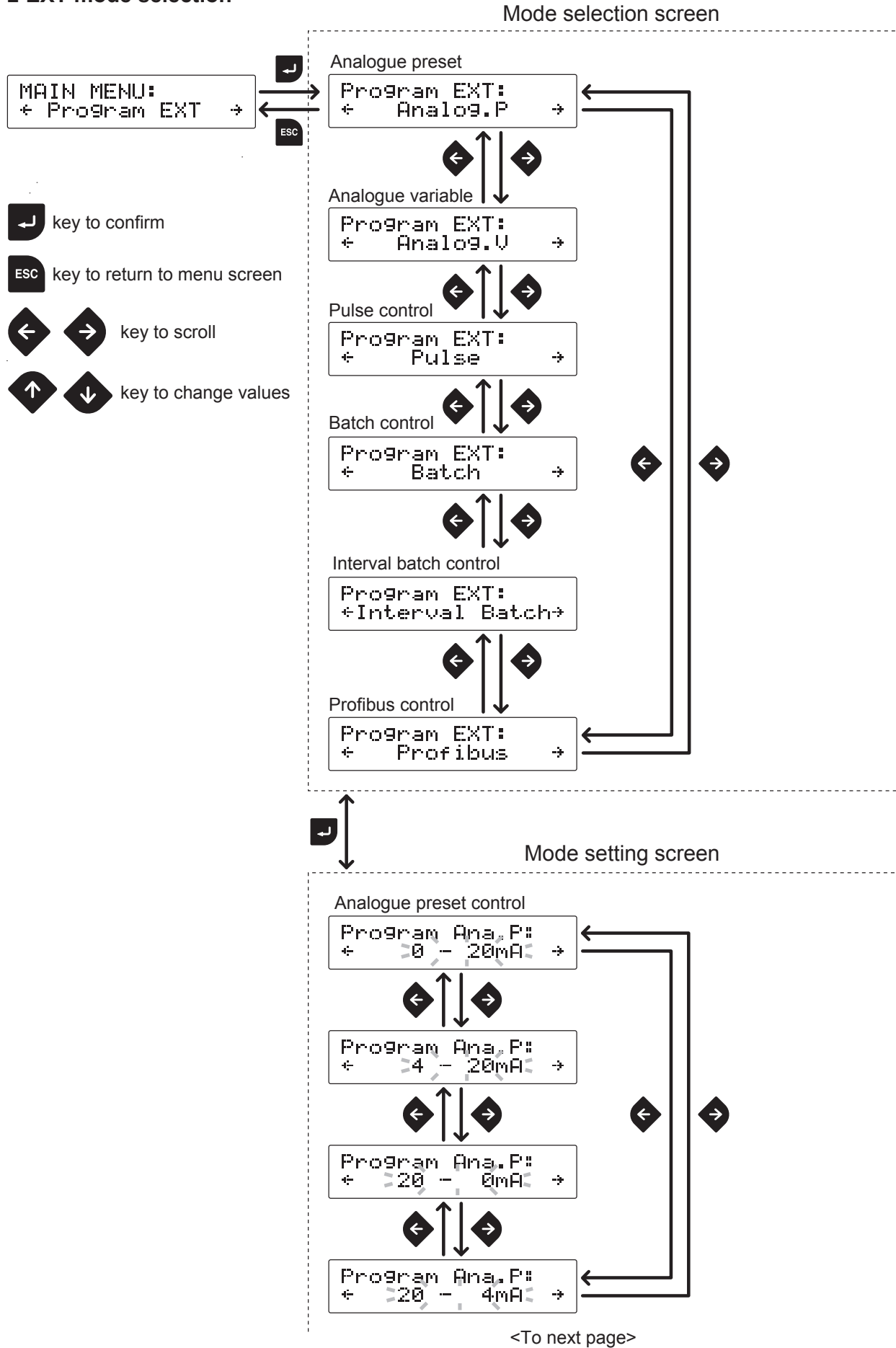

Analogue variable control

SP1 current setting

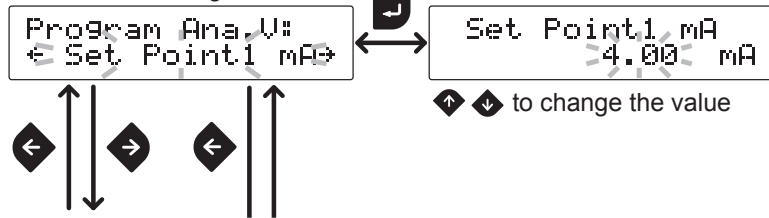

SP1 flow rate setting

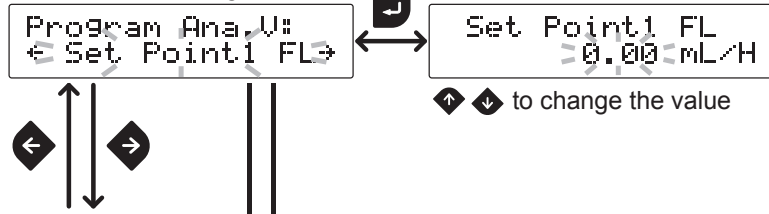

SP2 current setting

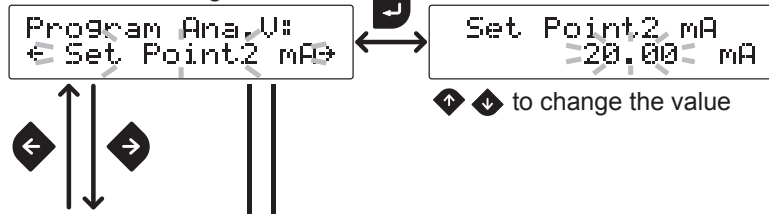

SP2 flow rate setting

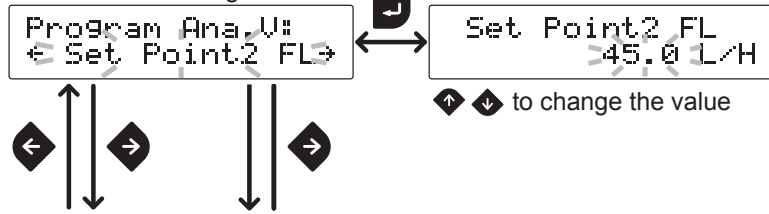

Behavioural pattern selection

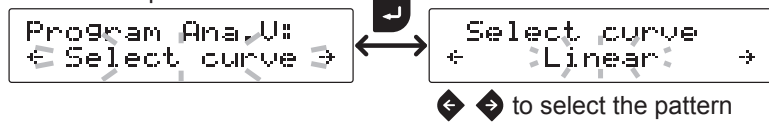

Pulse control

Program Pulse:
0.00375 mL/PLS Set flow volume per pulse.

Batch control

Program Batch:
3.75 mL/PLS Set flow volume per pulse.

<To next page>

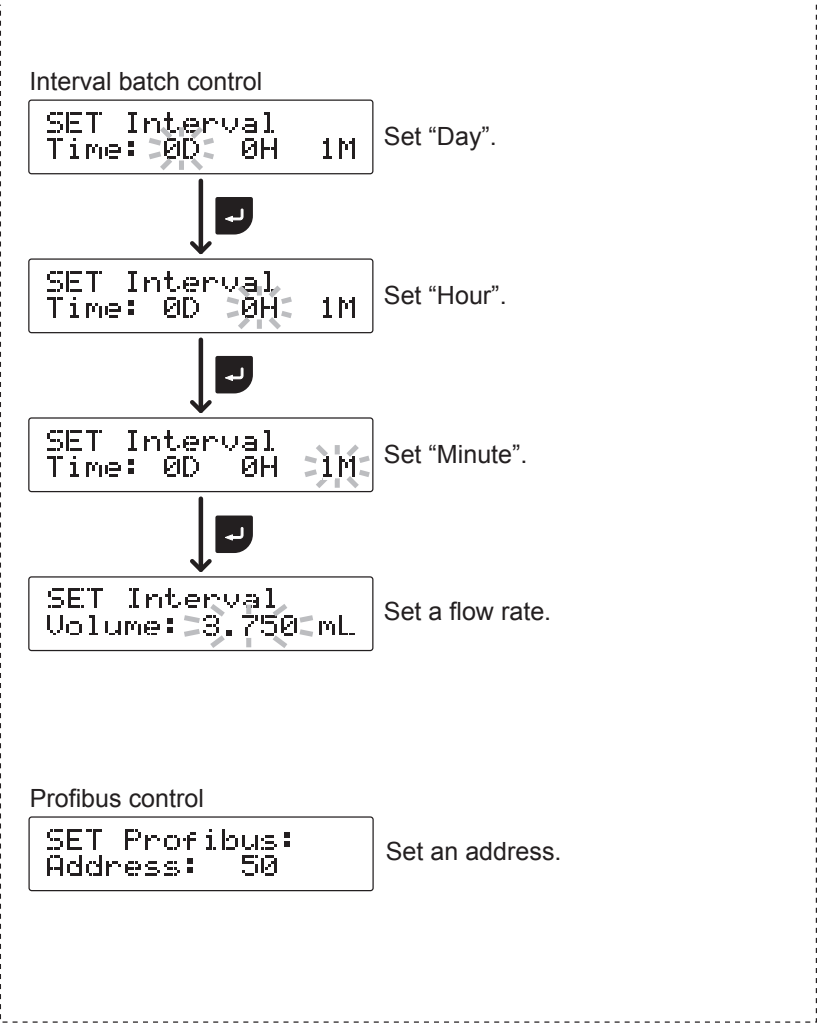

■ Calibration

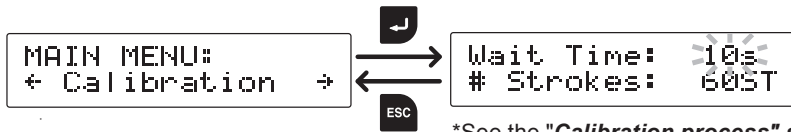



*See the "Calibration process" section on page 41 for detail.

 key to confirm

 key to return to menu screen

  key to select

  key to change values

■ Signal input setting

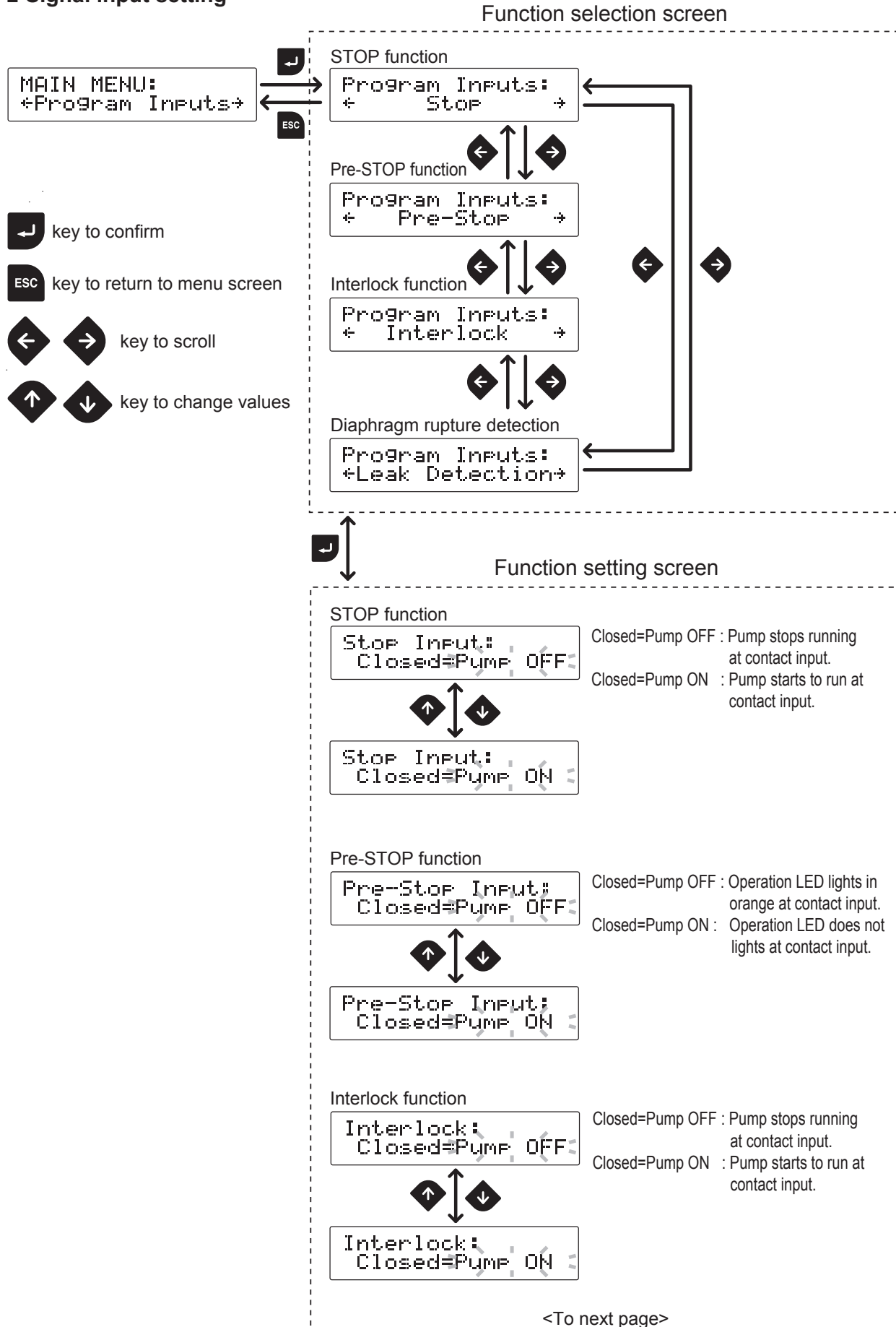

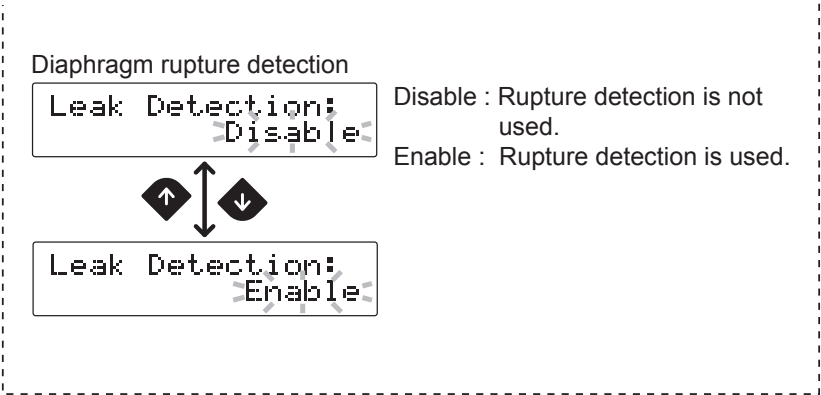

■ Analogue output setting

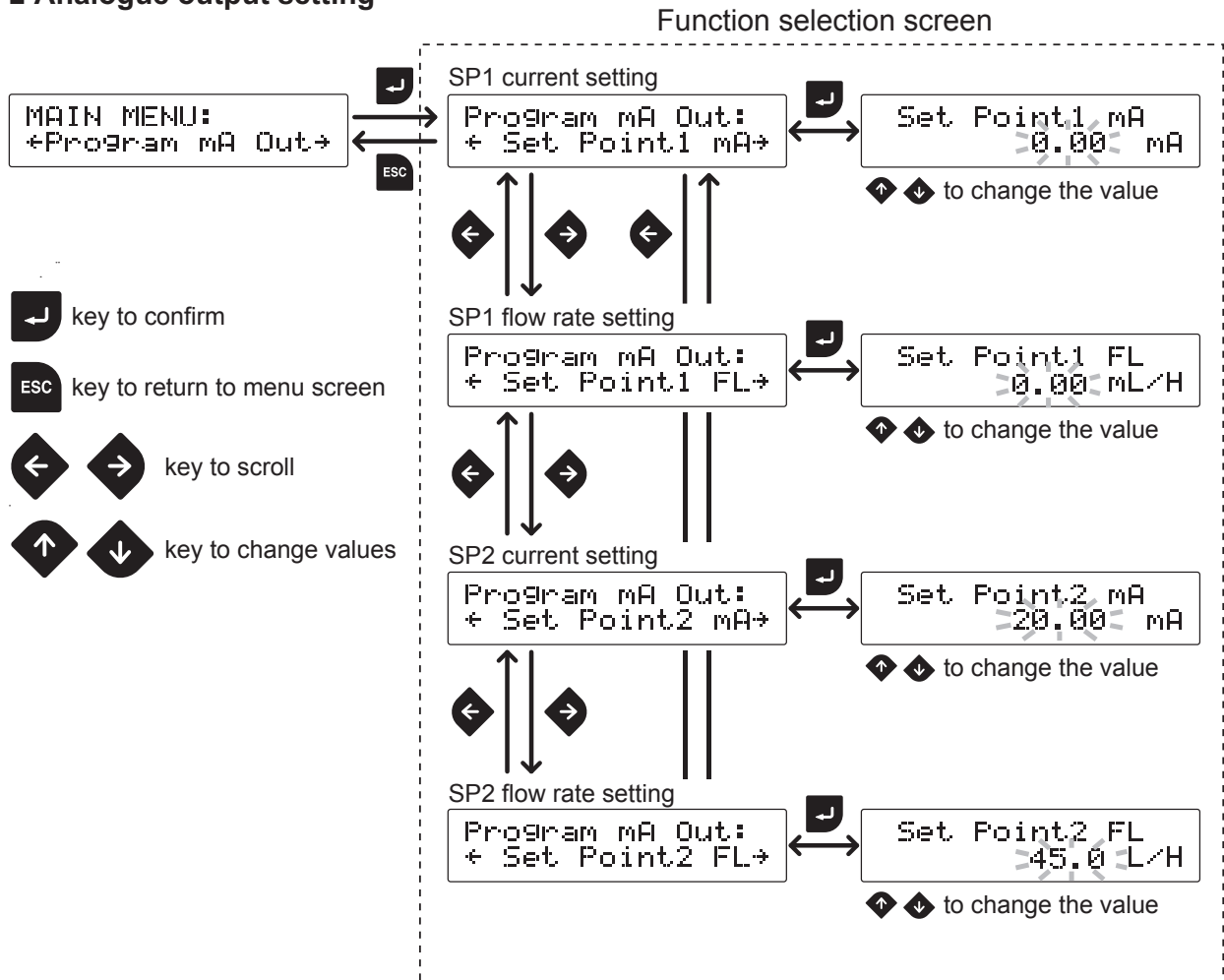

■ Alarm output setting (OUT 1) <Mechanical relay>

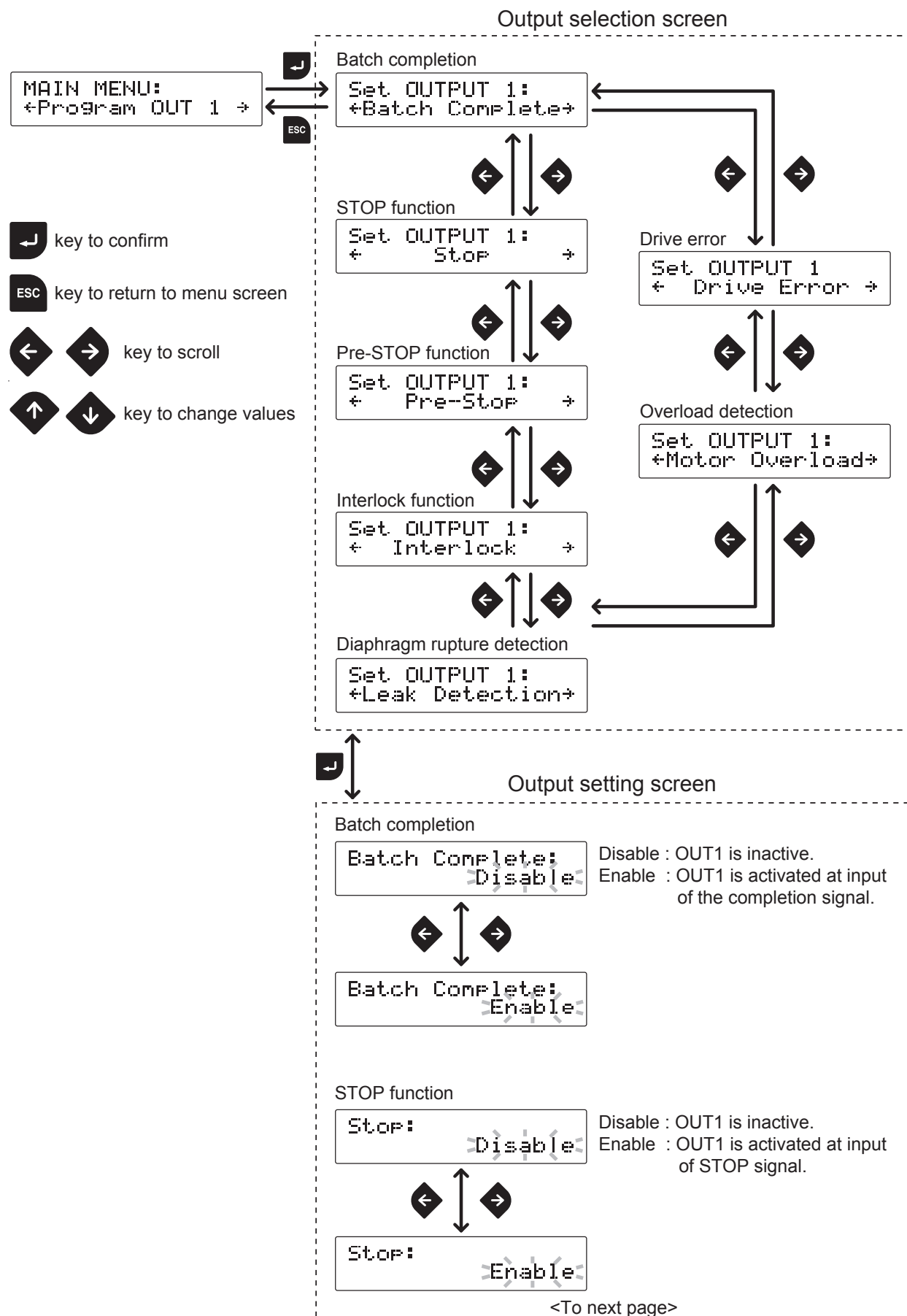

Operation

Pre-STOP function

Pre-Stop: Disable

Disable : OUT1 is inactive.
Enable : OUT1 is activated at input of Pre-STOP signal.



Pre-Stop: Enable

Interlock function

Interlock: Disable

Disable : OUT1 is inactive.
Enable : OUT1 is activated at input of interlock signal.



Interlock: Enable

Diaphragm rupture detection

Leak Detection: Disable

Disable : OUT1 is inactive.
Enable : OUT1 is activated at input of the detection signal.



Leak Detection: Enable

Overload/Failed speed detection

Motor Overload: Disable

Disable : OUT1 is inactive.
Enable : OUT1 is activated at input of the detection signal.



Motor Overload: Enable

Drive error detection

Drive Error: Disable

Disable : OUT1 is inactive.
Enable : OUT1 is activated at input of the detection signal.



Drive Error: Enable

■ Alarm output setting (OUT 2) <PhotoMOS relay>

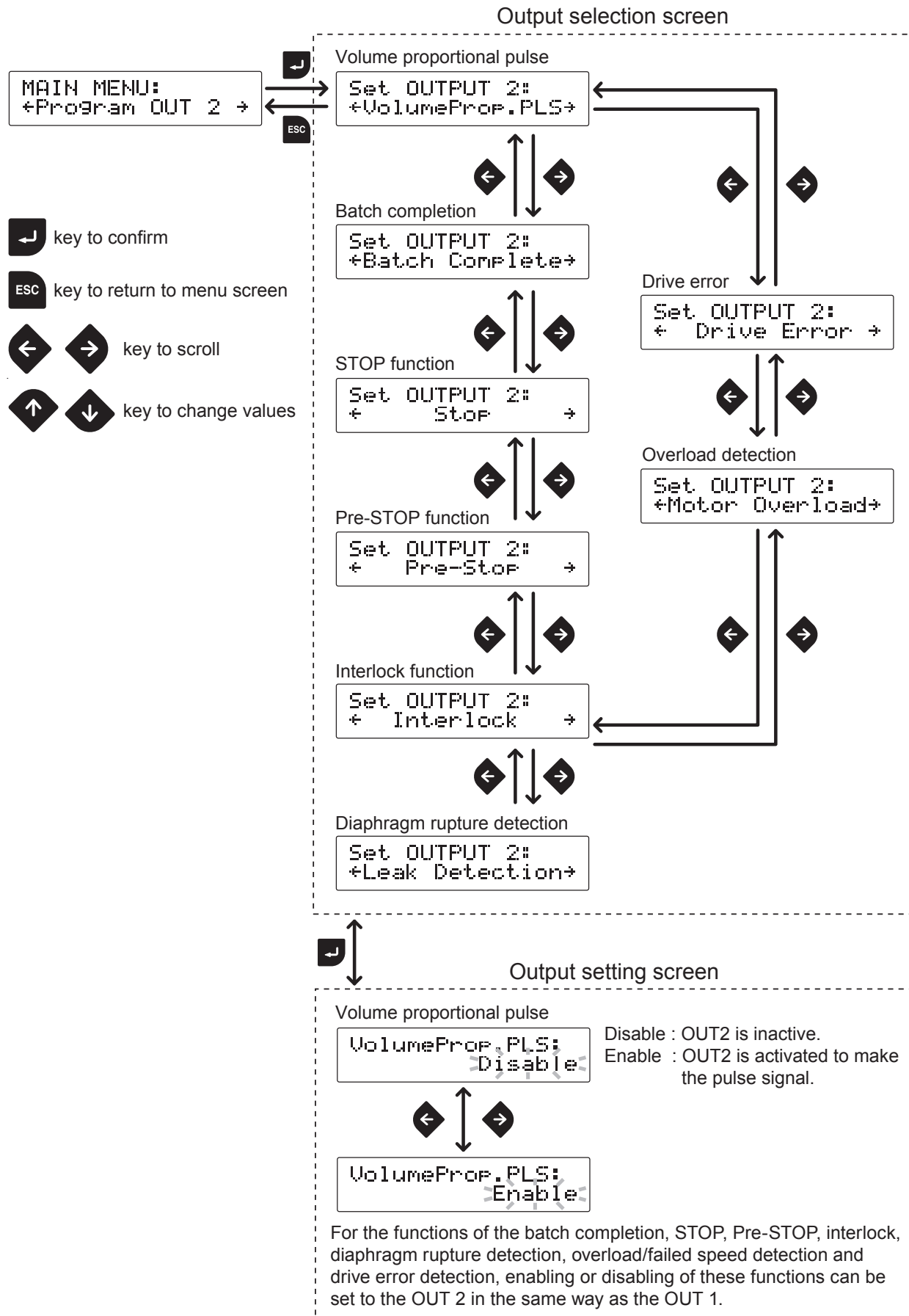

Operation

■ Data logging

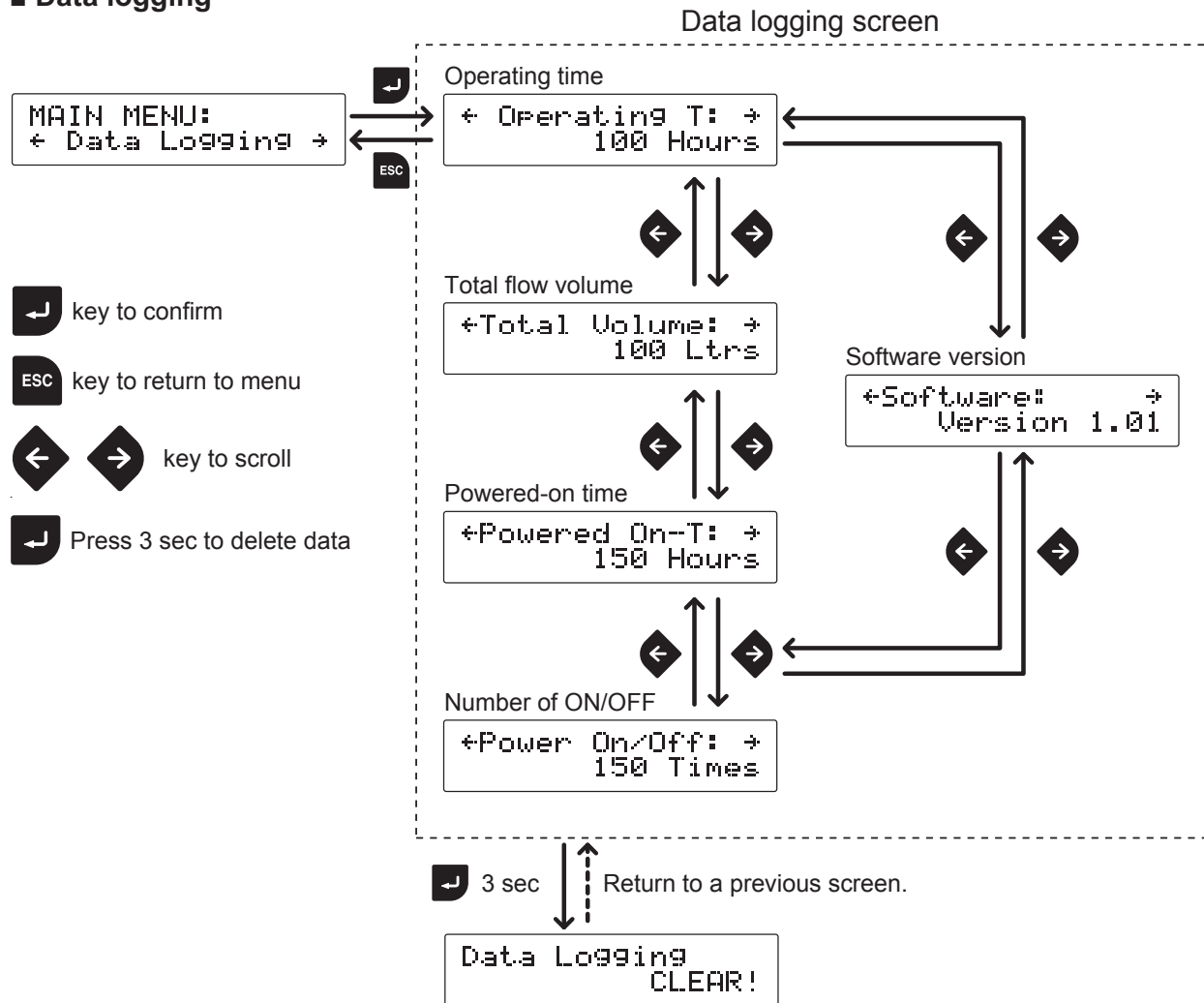

*A selected data will be cleared except the version information.

■ Setting of other functions

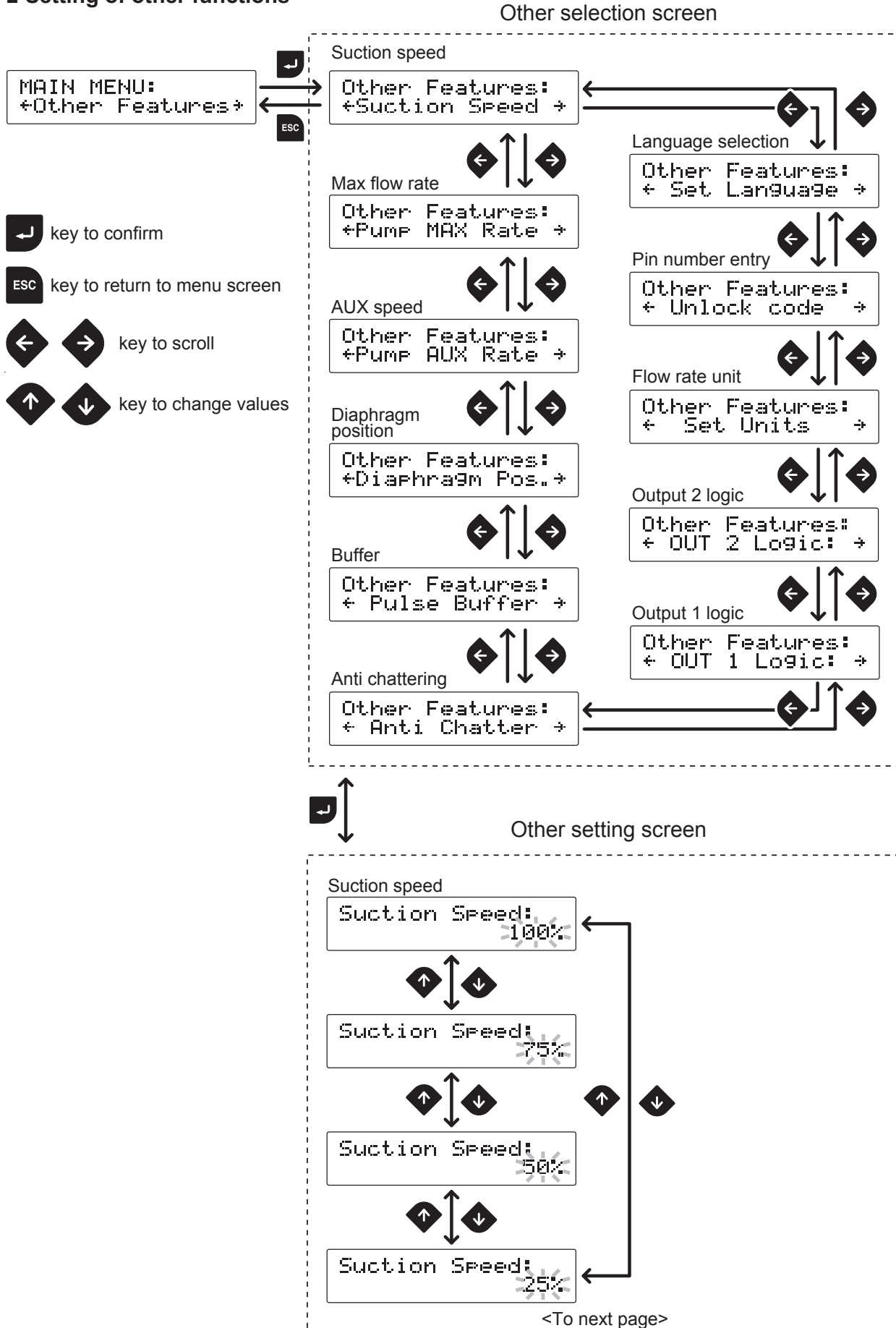

Max flow rate

Pump MAX Rate:
45.0 L/H

Set a flow rate.

AUX speed

Pump AUX Rate:
15.0 L/H

Set a flow rate.

Diaphragm position

Diaphragm Pos.:#
← MAX OUT Pos. →

Diaphragm Pos.:#
← MAX IN Pos. →

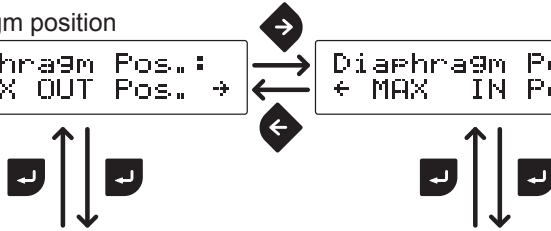

Diaphragm Pos.:#
MAX OUT Pos.:

Diaphragm Pos.:#
MAX IN Pos.:

MAX OUT Pos. : The diaphragm comes to the top dead point.

MAX IN Pos. : The diaphragm comes to the bottom dead point.

*Either one of the above indication keeps flashing as long as the diaphragm is at either end. See page 67 for diaphragm replacement.

Buffer

Pulse Buffer:
Disable

Disable : Buffer OFF

Enable : Buffer ON



Pulse Buffer:
Enable

Anti chattering

Anti Chatter:
5 msec



Anti Chatter:
1 msec



Anti Chatter:
2 msec

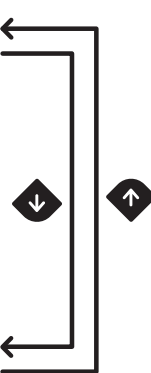

<To next page>

Output 1 logic

```
OUT 1 Logic:  
Normally open
```

Set the output 2 logic as necessary.



```
OUT 1 Logic:  
Normally close
```

Flow rate unit

```
Set Units:  
Liter
```



```
Set Units:  
US Gallon
```

Pin number entry

```
Unlock code:  
00000
```

- key to change values
- key to move through each digit
- key to confirm

Language selection

```
Set Language:  
English
```



```
Set Language:  
Dutch
```



```
Set Language:  
French
```



```
Set Language:  
Danish
```



```
Set Language:  
Spanish
```



```
Set Language:  
German
```



Operation

Operation

Read this section before operation.

Manual operation

Run or stop the pump by keypad operation.

- 1** Supply the rated power voltage to the pump.
The white LED bar flashes and the pump turns on.
*The pump enters the MAN/EXT selection mode when turning on power with the factory default setting.
- 2** Push the ESC key to enter the MAN/EXT selection mode.
Push the start/stop key to stop operation and then the ESC key if the IX is running in the MAN mode.

```
SELECT OPERATION  
MAN ← →EXT(ANA.P)
```

- 3** Push the left key to select the "MAN" option and the enter key for confirmation.
The pump enters a waiting state. Use the UP and DOWN keys to set the flow rate.

```
Standby (Manual)  
45.0 L/H
```

- 4** Push the start/stop key to run the pump in the MAN mode.
The green LED bar lights/runs during operation.

```
Pump On (Manual)  
45.0 L/H
```

EXT operation

The pump operation is controlled by the external signal.

- 1** Supply the rated power voltage to the pump.
The white LED bar flashed and then lights in the EXT mode.
*The pump enters the MAN/EXT selection mode when turning on power with the factory default setting.
- 2** Push the ESC key to enter MAN/EXT selection mode.
Push the start/stop key to stop operation and the ESC key if the IX is running in the EXT mode.

```
SELECT OPERATION  
MAN ← →EXT(ANA.P)
```

- 3** Push the right key to select "EXT" and the enter key for confirmation.

```
SELECT OPERATION
MAN← →EXT(ANA.P)←
```



```
Standby (EXT)
Analog Preset
```

Waiting state display

*The pump enters the analog preset, analog variable, pulse, batch, interval batch, or Profibus mode.

- 4** Push the start/stop key to start the EXT operation. The pump runs along with operation settings and the external signal. Pushing the same key again stops operation. In the analog variable control mode, the current value will show up when the → key is pushed. Push the ← key to return.

```
PUMP On (Ana.P)
      00.0 mL/H
```

The green LED lights/runs during operation.

AUX function

Operation at an AUX speed starts while receiving the external signal via the AUX terminal when the IX is running in manual mode or EXT mode. Set an AUX speed before operation. See page 55 for detail.

Priming function

This key operation runs the pump at the preset maximum flow rate.

- 1** Press and hold both the UP and DOWN keys.

The pump runs at the preset maximum flow rate while both the keys are pressed.

*This function is available at any time except when the MAN/EXT selection or the menu screen is opened.

```
PRIMING OVERRIDE
      45.0 L/H
```

Keypad lock

Keypad lock can be active for the prevention of erroneous key operation.

NOTE

- Any key operation is not acceptable when the keypad lock is active. In an emergency, however, pressing the start/stop key for two seconds or a longer period will stop the pump. Enter the PIN number to unlock keypads before resuming operation.
- Keypads can be locked at any time except when the menu screen is opened.

■ Keypad lock activation

- 1 Press and hold both the right and left keys for 3 seconds.

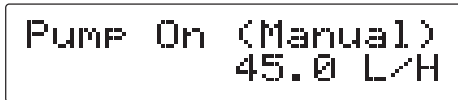

Pump On (Manual)
45.0 L/H



KEY LOCKED!

"KEY LOCKED!" appears on the screen for one second.

*This indication comes up every time any key is pushed.

■ Keypad lock release

- 1 Push the ESC key.

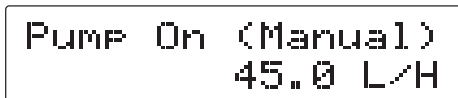

Pump On (Manual)
45.0 L/H

- 2 Enter the PIN number.



UNLOCKED CODE?
0 0 0 0 0

↑ ↓ key to change value

◀ ▶ key to move through each digit



KEY UNLOCKED!

■ Emergency stop

- 1 Press and hold the start/stop key for 2 seconds to stop the pump.
Unlock keypads to resume operation.

Maintenance

This section describes troubleshooting, maintenance, wear part replacement, exploded views and specifications.

! Points to be observed

Observe the following points during maintenance work:

- Observe instructions in this manual for maintenance, inspection, disassembly and assembly. Do not take apart the pump beyond the extent of the instructions.
- Always wear protective clothing such as an eye protection, chemical resistant gloves, a mask and a face shield during disassembly, assembly or maintenance work. The specific solution will dictate the degree of protection. Refer to SDS precautions from the solution supplier.
- Risk of electrical shock. Be sure to turn off power to stop the pump and related devices before service is performed.

Before unplugging the pump:

Always stop the pump by key operation and wait for three seconds, so the pump can save the stop command for sure. If the stop command is not saved properly, the pump may unintentionally start to run when it is powered on.

NOTE

- It's not the manufacture's responsibility for any failure due to corrosion or erosion occurred in your operating condition.
- For the need of repair, your distributor of Iwaki or the manufacturer of equipment in which our product is built.
- Be sure to drain chemicals and flush the inside of the pump before return so that a harmful chemical does not spill out in transit.

Troubleshooting

First check the following points. If the following measures do not help remove problems, contact your nearest distributor.

■ Pump

States	Possible causes	Solutions
The pump does not run (the LED bar does not light, or the screen is blank.).	Power voltage is too low.	• Observe the allowable voltage range of 90-264VAC.
	The pump is not powered.	• Check the pump is switched on. • Correct wiring. • Replace a breaking wire to new one.
Liquid can not be pumped up.	Air lock in the pump	• Expel air. See page 39.
	Entrained air from a suction line connection	• Fix the connection/reroute the suction line as necessary.
	A missing O ring from a valve set.	• Fit the O ring to the valve set.
	Debris is stuck in the pump head valves.	• Disassemble, inspect and clean the valves. Replace as necessary.
	A ball valve is stuck on a valve seat.	• Disassemble, inspect and clean the valves. Replace as necessary.
	A valve seat has been pressed in the valve guide.	• Do not push the valve seat into the valve guide. See page 67.
A flow rate fluctuates.	Air trapped in the pump head.	• Expel air. See page 39.
	Overfeeding occurs.	• Mount a back pressure valve to keep the discharge line pressure constant.
	Debris is stuck in the pump head valves.	• Disassemble, inspect and clean the valves. Replace as necessary.
	The diaphragm unit is broken.	• Replace the diaphragm set. See page 67.
	Pressure fluctuates at the injection point.	• Maintain the pressure constant by optimizing piping or by relocating the injection point.
Liquid leaks.	The nut is loose.	• Tighten the nut to fix the fitting.
	Loose fit of the pump head	• Retighten the pump head. See page 38.
	An O ring is not fitted to a valve set.	• Fit O ring to the valve set. See page 67.
	The diaphragm unit is broken. A leak from the drain port (vent hole)	• Replace the diaphragm set. See page 69.

Error messages

Take measures below when any of the error messages appears during operation. Contact us or your nearest distributor as necessary.

Error messages	Possible causes	Measures
MOTOR OVERLOAD! S/S Key = Clear ↑ shows up in turn CHECK PLUMBING BEFORE CLEARING!	The pressure overload protection is active.	<ul style="list-style-type: none"> Check a discharge line for clogging and remove it as necessary. If this error happens during the transfer of high viscosity liquid, make a discharge line I.D. wider and its length shorter.
LEAK DETECTED! S/S Key = Clear	The diaphragm unit is broken.	<ul style="list-style-type: none"> Replace the broken diaphragm set with the new one. See page 67 for detail.
DRIVE ERROR! S/S Key = Clear	Rotation control is failed.	<ul style="list-style-type: none"> If this error state is removed by pushing the start/stop key, a possible cause is an instantaneous surge of discharge line pressure. Inspect/solve the problem and then restart. If not, the failure of a motor rotation detector is possible. Contact us or your nearest distributor.

Inspection

Perform daily and periodic inspection to keep the best pump performance and safety.

Daily inspection

Check the following points. If you notice any abnormal or dangerous conditions, suspend operation immediately and inspect/solve problems. See the "Troubleshooting" section as necessary.

When wear parts come to the life limit, replace them with new ones. Contact us or your distributor for detail.

No.	States	Points to be checked	How to check
1	Pumping	• If liquid is pumped.	Flow meter, pressure gauge or visual inspection
		• If discharge pressure is normal.	Pressure gauge
		• If liquid is deteriorated, crystallized or settled.	Visual or audio inspection
2	Noise and vibration	• If abnormal noise or vibration occurs. They are signs of abnormal operation.	Visual or audio inspection
3	Entrained air from the pump head joints and the suction line	<ul style="list-style-type: none"> If leakage occurs. If pumped liquid includes air bubbles, check lines for leakage and retighten as necessary. 	Visual or audio inspection

Periodic inspection

Retighten the pump head mounting bolts evenly to the following torque in diagonal order.

*Mounting bolts may loosen in operation. How fast the bolts start to loosen is depending on operating conditions.

Tightening torque

Model code	Torque	Bolts	Number of bolts
IX-B007/-B015/-B030/-B045	3 N•m	M5 hexagon head bolt	4



Wear part replacement

To run the pump for a long period, wear parts need to be replaced periodically. It is recommended that the following parts are always stocked for immediate replacement. Contact your nearest distributor for detail.

! Precautions

- Solution in the discharge line may be under pressure. Release the pressure from the discharge line before disconnecting plumbing or disassembly of the pump to avoid solution spray.
- Rinse wet ends thoroughly with tap water.
- Every time the pump head is disassembled, replace the diaphragm and the valve sets with new ones.

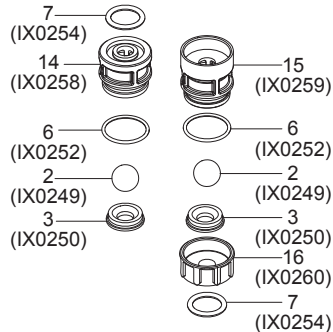
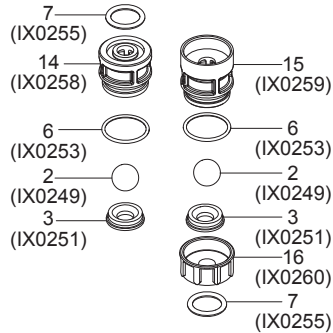
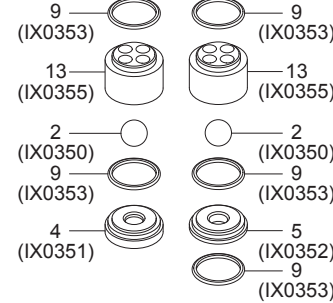
Wear part list

Pump head	Parts	# of parts	Estimated life
B007/B015		2 sets (inlet/outlet)	8000 hours or 1 year*
		2 sets (inlet/outlet)	8000 hours or 1 year*
		2 sets (inlet/outlet)	8000 hours or 1 year*
		1 sets	4000 hours or 6 months*

*1 year or 6 months is from after start of use.

*Wear part duration varies with the pressure, temperature and characteristics of liquid.

*The estimated life is calculated based on pumping clean water at ambient temperature.

*Parenthetic codes are selection codes.

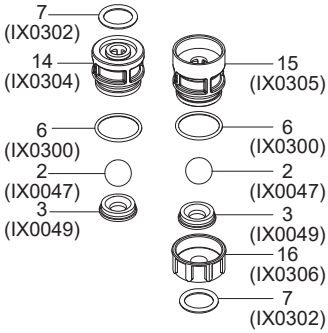
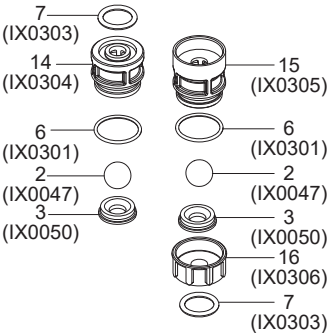
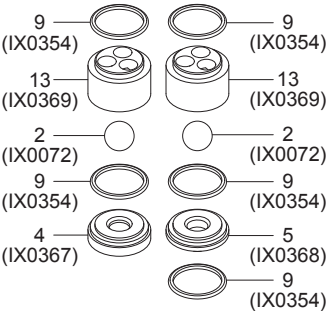
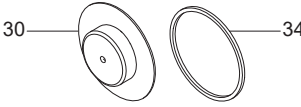
Pump head	Parts	# of parts	Estimated life
B030/045	Valve set TC type (IX0319) 	2 sets (inlet/outlet)	8000 hours or 1 year*
	Valve set TE type (IX0320) 	2 sets (inlet/outlet)	8000 hours or 1 year*
	Valve set S6 type (IX0371) 	2 sets (inlet/outlet)	8000 hours or 1 year*
	Diaphragm set (IX0321) 	1 set	4000 hours or 6 months*

*1 year or 6 months is from after start of use.

*Wear part duration varies with the pressure, temperature and characteristics of liquid.

*The estimated life is calculated based on pumping clean water at ambient temperature.

*Parenthetic codes are selection codes.

Before replacement

1 Stop the pump operation.

2 Close the suction line.

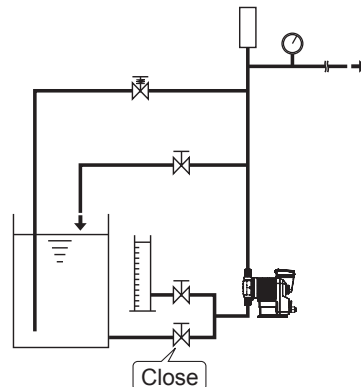

3 Open the drain valve to release liquid out of the discharge line.

NOTE

Open the valve gradually. Solution flows out fast if solution in the discharge line is under pressure.

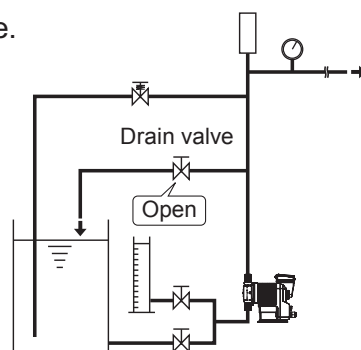

Valve set replacement

1 Remove pipes from the pump.

NOTE

- Be careful not to get wet with residual chemicals in piping.
- Rinse chemicals or crystals off the parts as necessary.
- Use care handling the valve set. Do not drop it especially when the suction pipe is removed from the pump inlet.
- For the pumps with the TC/TE wet end code, remove the nuts while holding the adapter with a spanner.

IX-B TC/TE

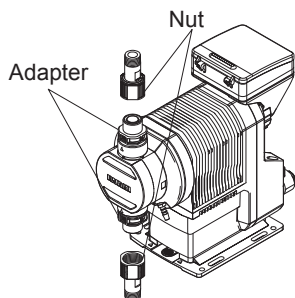

- 2** Take out valve sets from the pump head and take them apart to replace worn parts as necessary.
Clean the pump head as necessary.

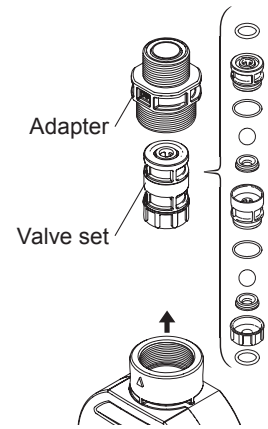

- 3** Reassemble and remount the valve sets in the pump head.

Observe the mounting order and direction of valve set components. See the exploded view as well.

NOTE

- Observe the mounting direction of the valve set.
- For the pumps with the TC/TE wet end code. Do not push the valve seat down into the valve guide. A leak may result.

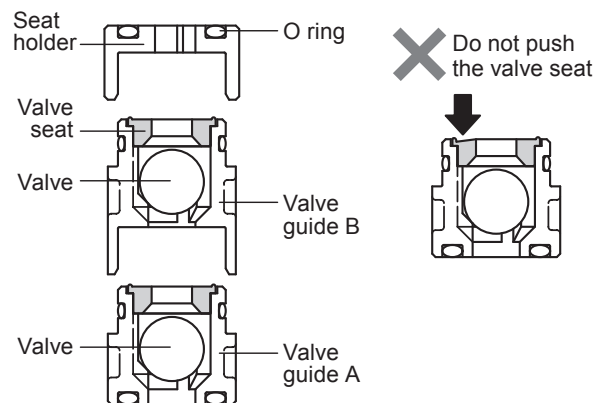

- 4** Connect pipes and the pump.

For the pumps with the TC/TE wet end code, tighten the plastic "adapter" by 5N•m. Do not use excessive force or it may break.

Diaphragm set replacement

Necessary tools

- 4mm hexagon wrench
- Torque wrench

1 Remove pipes from the pump.

NOTE

Be careful not to get wet with residual chemicals in the pump head or the discharge pipe.

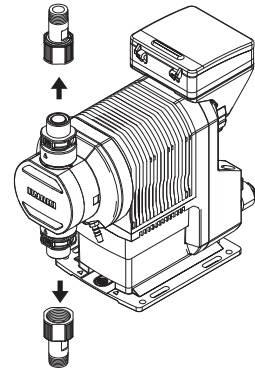

2 Remove the bolt cover (pumps with TC/TE wet ends).

Push the clicks at the both sides and remove the bolt cover.

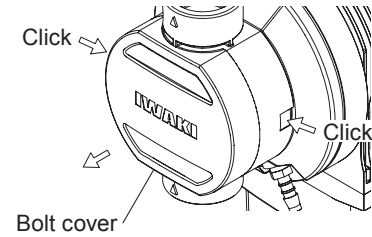

3 Use the M5 hexagon wrench to remove the four M5 bolts and then the pump head.

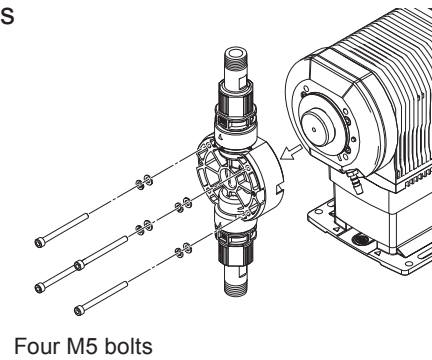

4 Extend the pump shaft by keypad operation.

*With the diaphragm rupture detection ON and the error message of "LEAK DETECTED!", the diaphragm has been fully extended. In this instance, skip to the next step.

```
Other Features:
+Diaphragm Pos.+
```

Select the "Diaphragm Pos." option through the menu screen and push the enter key. See page 55 for detail.

```
Diaphragm Pos.:
+ MAX OUT Pos.+
```

Select the "MAX OUT Pos." option by the right and left keys and push the enter key.

```
Diaphragm Pos.:
 MAX OUT Pos.:
```

The diaphragm extends to the maximum and the "MAX OUT Pos." option blinks on the screen.

5 Rotate and remove the diaphragm unit and gasket.

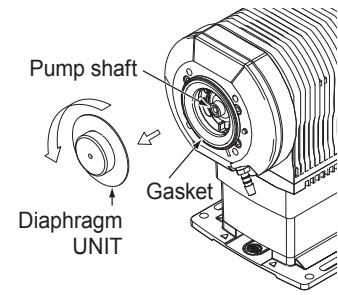

6 Fit a new diaphragm unit and gasket.

Tighten it until bottoms out and will not turn further.

NOTE

If it is fitted loose, failure may result.

7 Retract the pump shaft by keypad operation.

```
Diaphragm Pos.:  
MAX OUT Pos.:
```

Push the enter key.



```
Other Features:  
←Diaphragm Pos.→
```

Select the "Diaphragm Pos." option and push the enter key.



```
Diaphragm Pos.:  
← MAX OUT Pos. →
```

Select the "MAX IN Pos." option by the right and left keys.



```
Diaphragm Pos.:  
← MAX IN Pos. →
```

Push the enter key.



```
Diaphragm Pos.:  
MAX IN Pos.:
```

The diaphragm contracts and the "MAX IN Pos." option flashes.

8 Mount the pump head.

Tighten the bolts evenly to 3N·m in diagonal order.

NOTE

Check the pump shaft has contracted to the full before mounting the pump head, or a leak or damage may result.

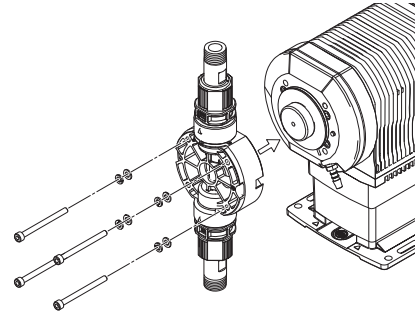

9 Remount the bolt cover (pumps with TC/TE wet ends).

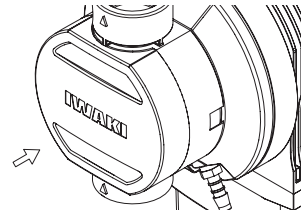

10 Connect pipes to the fittings and then tighten the nuts.

NOTE

Make sure O rings and gaskets are fitted properly.

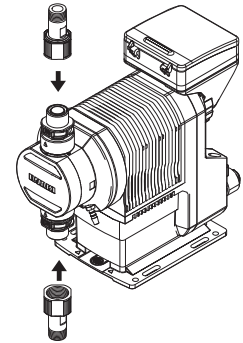

11 Go back to the waiting state.

Other Features:
←Diaphragm Pos.→

Push the enter key once to return.



SELECT OPERATION
MAN← →EXT(ANA.P)

Push the start/stop key to return to the MAN/EXT selection.

Exploded view

Pump head, Drive unit & Control unit

Do not disassemble the pump beyond the extent shown in the diagram below.

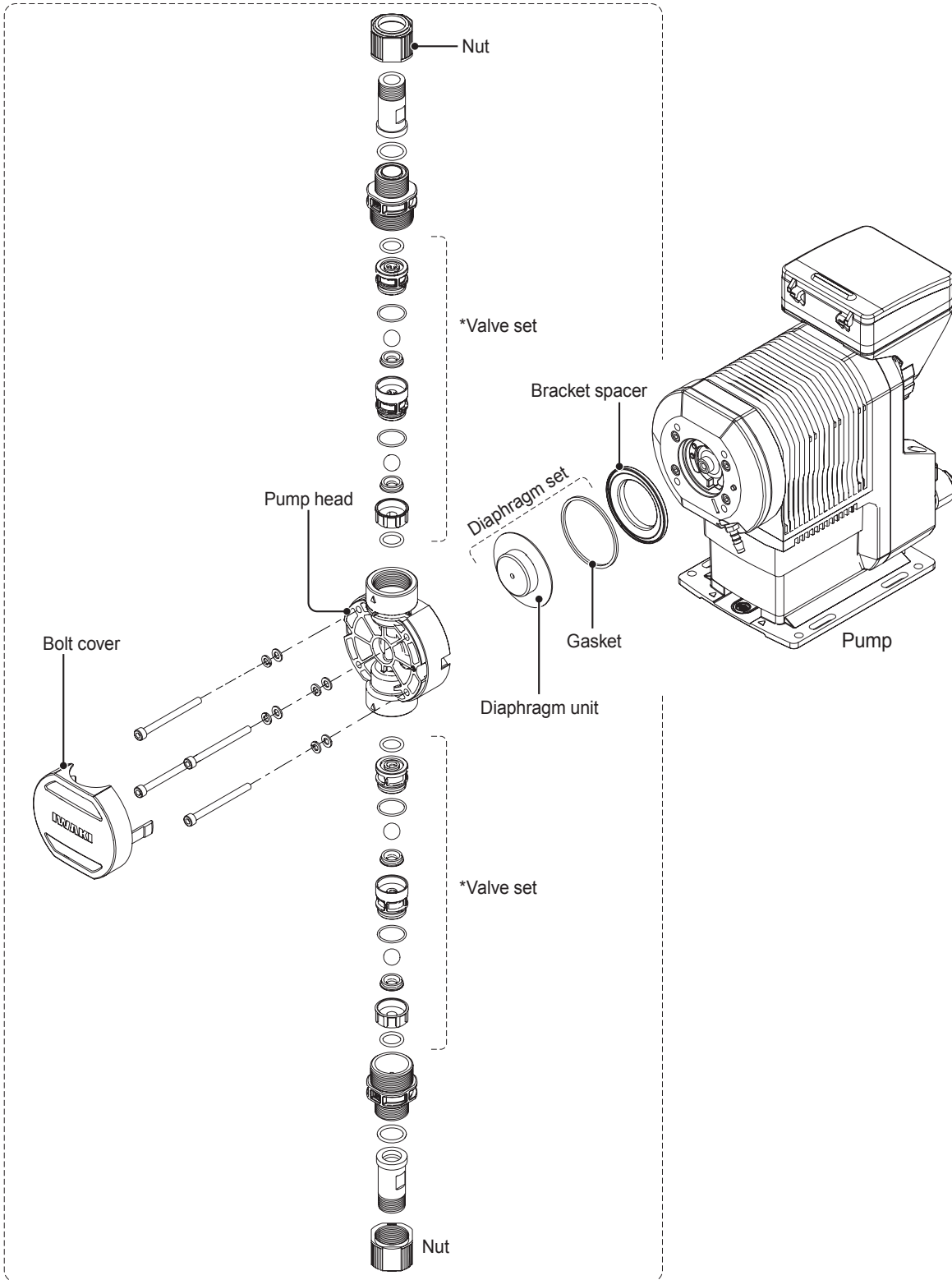

*Valve set materials differ with models.

Pump head

■ IX-B007/-B015/-B030/-B045 TC/TE R/N

No.	Part names	# of parts
1	Pump head	1
2	Valve	4
3	Valve seat	4
6	O ring	4
7	O ring	4
8	O ring	2
14	Valve guide A	2
15	Valve guide B	2
16	Seat holder	2
17	IN adapter	1
18	OUT adapter	1
19	Hex socket head bolt	4
20	Spring washer	4
21	Plain washer	4
28	Bolt cover	1
30	Diaphragm unit	1
34	Gasket	1
35	Bracket spacer	1
50	Nut	2
73	Fitting	2

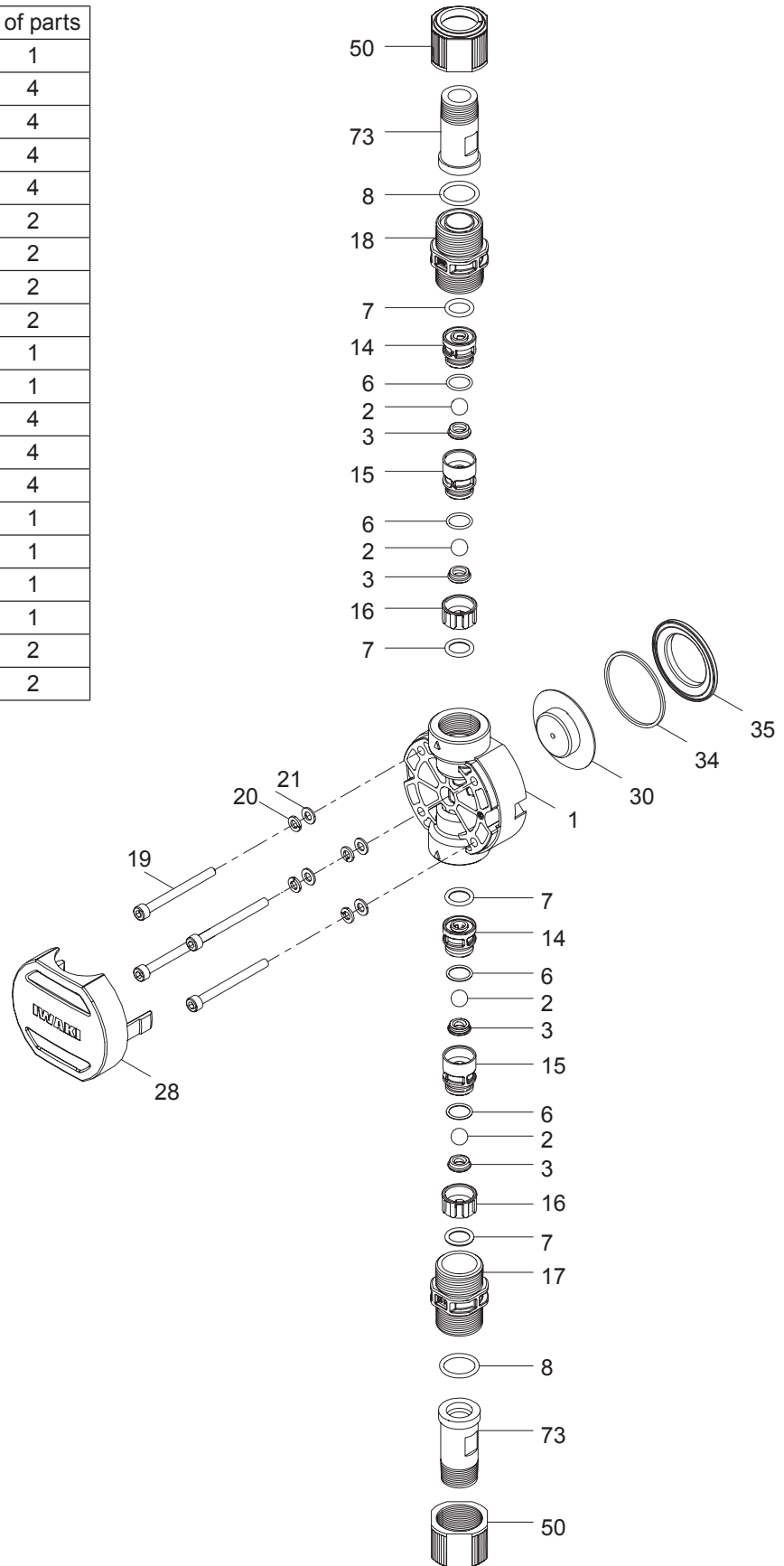

■ IX-B007/-B015/-B030/-B045 TC/TE G

No.	Part names	# of parts
1	Pump head	1
2	Valve	4
3	Valve seat	4
6	O ring	4
7	O ring	4
8	O ring	2
14	Valve guide A	2
15	Valve guide B	2
16	Seat holder	2
17	IN adapter	1
18	OUT adapter	1
19	Hex socket head bolt	4
20	Spring washer	4
21	Plain washer	4
28	Bolt cover	1
30	Diaphragm unit	1
34	Gasket	1
35	Bracket spacer	1

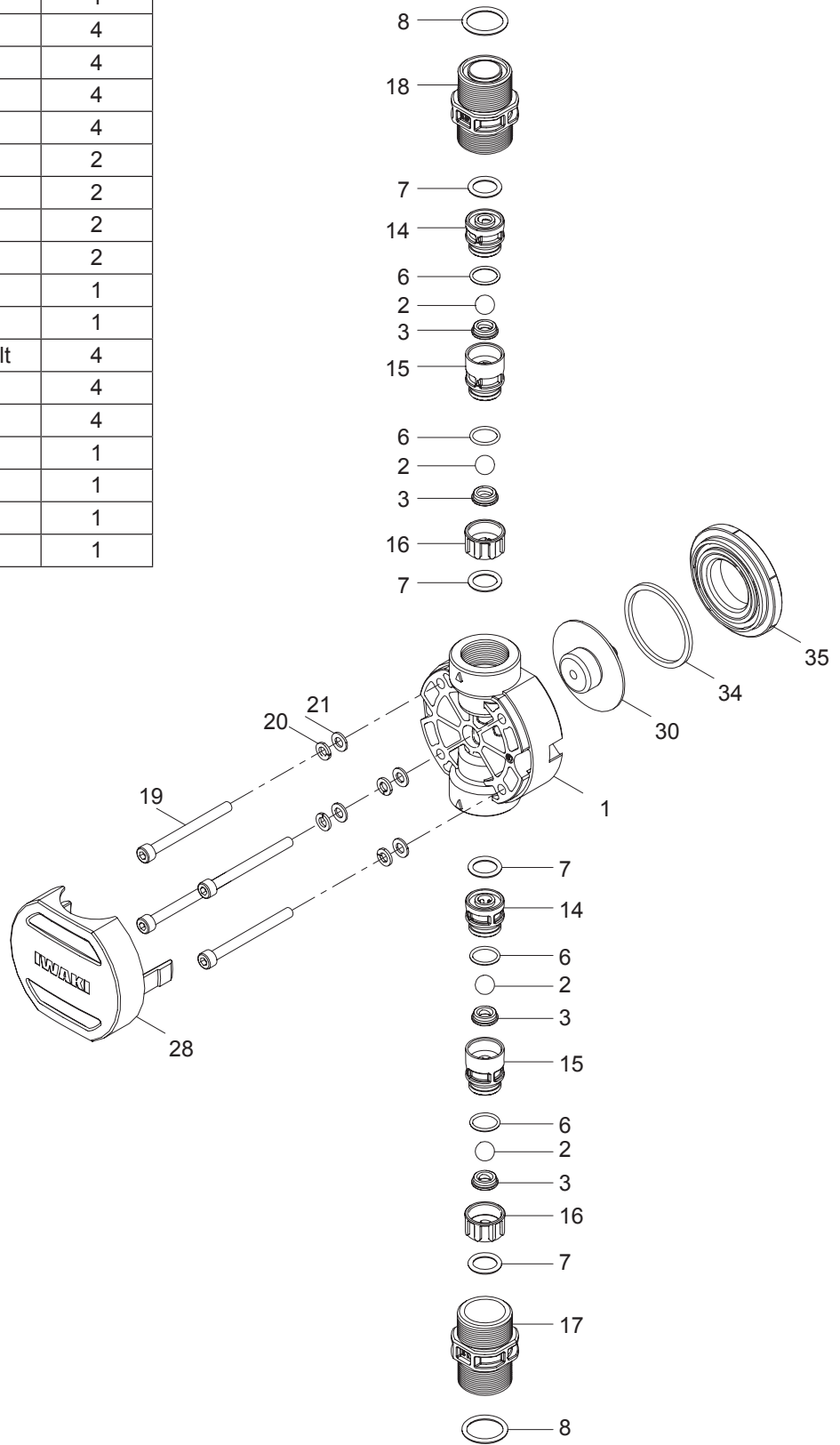

Maintenance

■ IX-B007/-B015/-B030/-B045 TC/TE F

No.	Part names	# of parts
1	Pump head	1
2	Valve	4
3	Valve seat	4
6	O ring	4
7	O ring	4
8	O ring	2
14	Valve guide A	2
15	Valve guide B	2
16	Seat holder	2
17	IN adapter	1
18	OUT adapter	1
19	Hex socket head bolt	4
20	Spring washer	4
21	Plain washer	4
28	Bolt cover	1
30	Diaphragm unit	1
34	Gasket	1
35	Bracket spacer	1
45	Flange unit	2

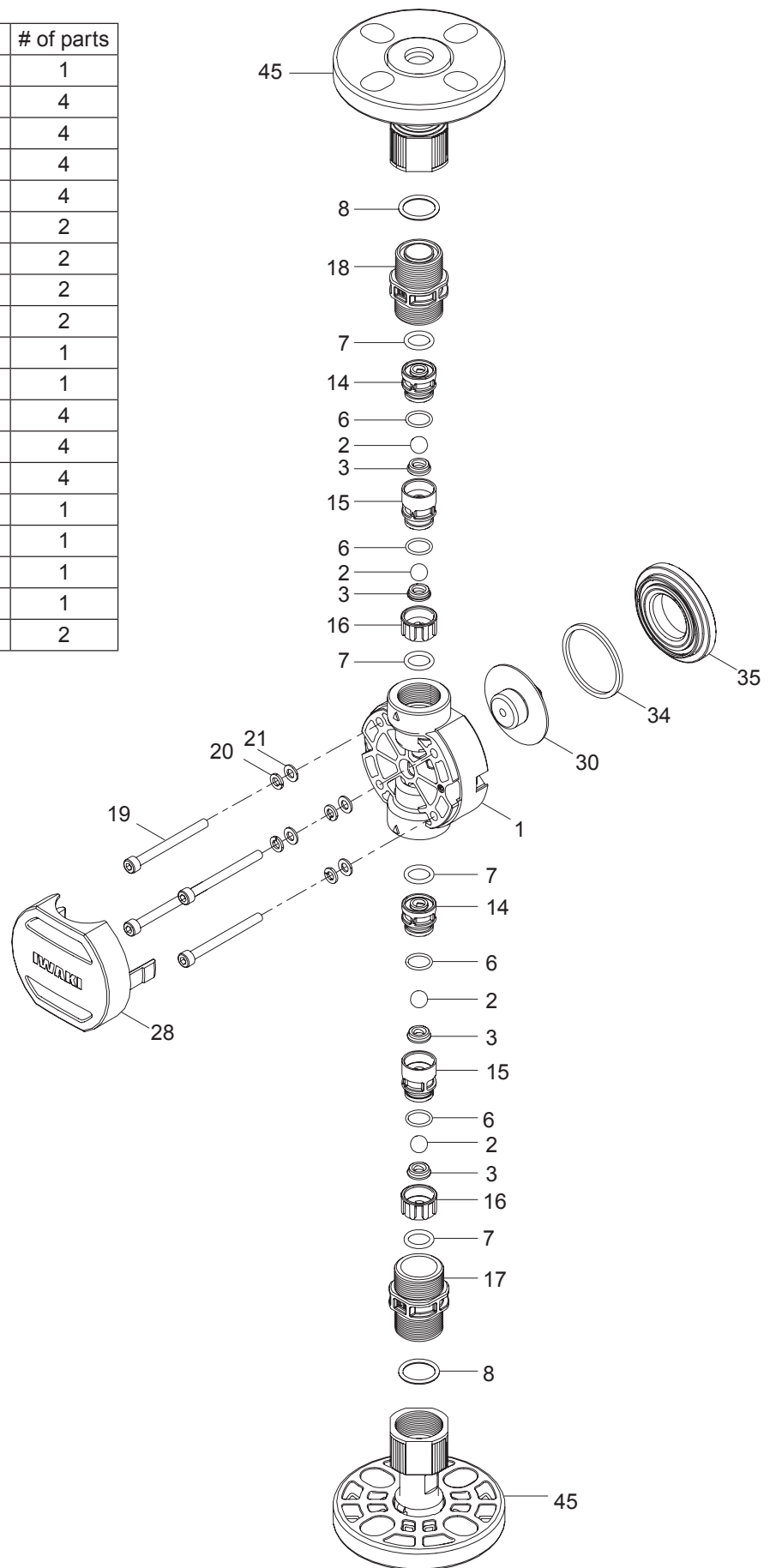

■ IX-B007/-B015/-B030/-B045 TC/TE T

No.	Part names	# of parts
1	Pump head	1
2	Valve	4
3	Valve seat	4
6	O ring	4
7	O ring	4
14	Valve guide A	2
15	Valve guide B	2
16	Seat holder	2
17	IN adapter	1
18	OUT adapter	1
19	Hex socket head bolt	4
20	Spring washer	4
21	Plain washer	4
28	Bolt cover	1
30	Diaphragm unit	1
34	Gasket	1
35	Bracket spacer	1
50	Nut	2
74	Hose stopper	2
75	Hose adapter	2
76	O ring	2

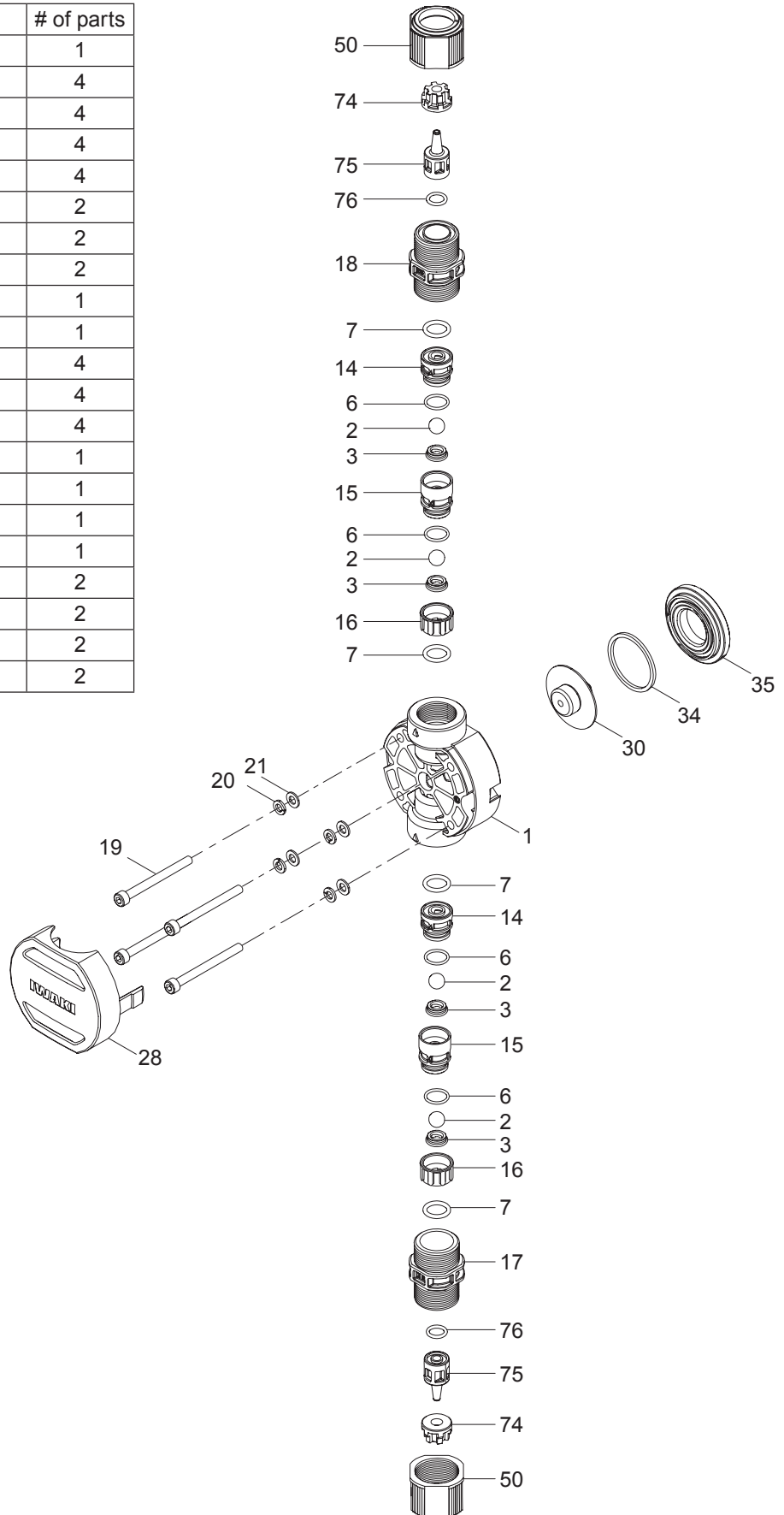

Maintenance

■ IX-B007/-B015/-B030/-B045 S6 R/N

No.	Part names	# of parts
1	Pump head	1
2	Valve	4
4	Valve seat A	2
5	Valve seat B	2
9	Valve gasket	10
10	Gasket	2
13	Valve guide	4
19	Hex socket head bolt	4
20	Spring washer	4
30	Diaphragm unit	1
(31)	Retainer	1
(32)	Diaphragm sheet	1
(33)	Diaphragm stopper	1
34	Gasket	1
35	Bracket spacer	1
50	Nut	2
57	Adapter	2
73	Fitting	2

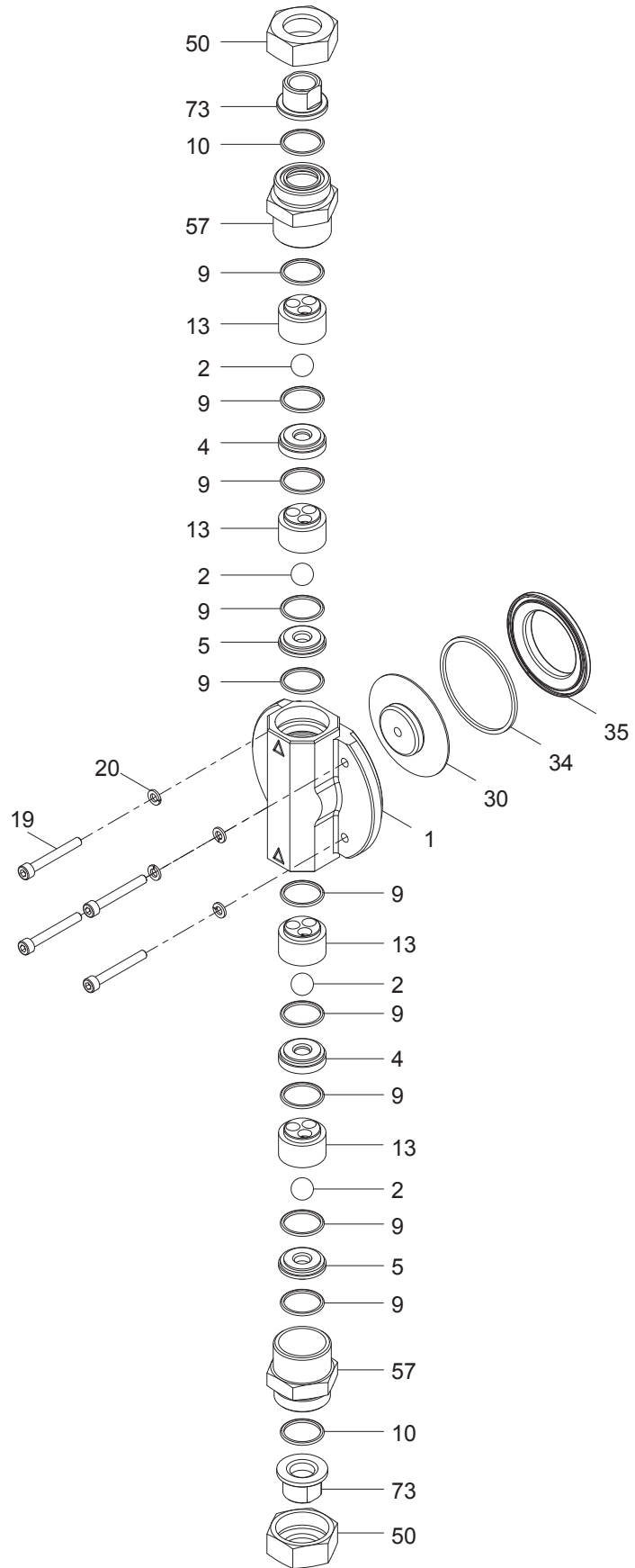

■ IX-B007/-B015/-B030/-B045 S6 FJ/FD/FA

No.	Part names	# of parts
1	Pump head	1
2	Valve	4
4	Valve seat A	2
5	Valve seat B	2
9	Valve gasket	10
10	Gasket	2
13	Valve guide	4
19	Hex socket head bolt	4
20	Spring washer	4
30	Diaphragm unit	1
(31)	Retainer	1
(32)	Diaphragm sheet	1
(33)	Diaphragm stopper	1
34	Gasket	1
35	Bracket spacer	1
45	Flange unit	2
57	Adapter	2

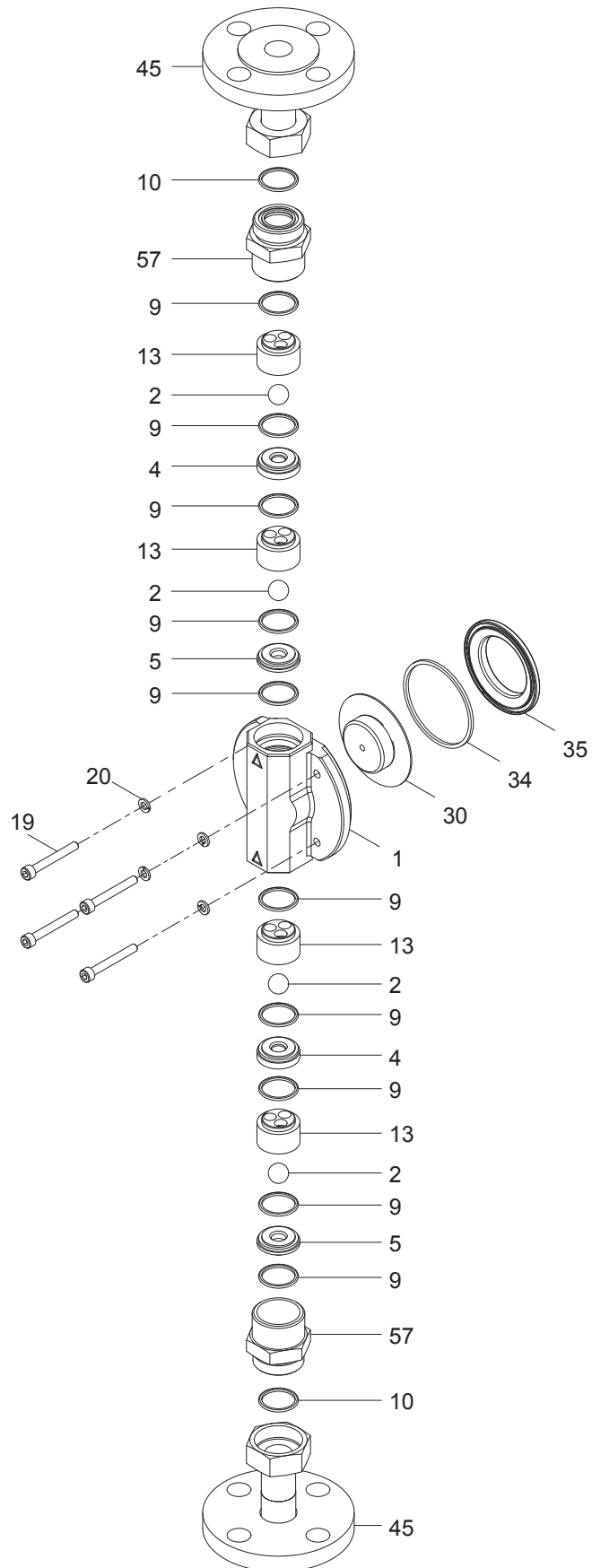

Maintenance

Specifications/Outer dimensions

Specifications

Information in this section is subject to change without notice.

■ Pump

Model code		Flow rate L/H	Max. discharge pressure MPa	Avg. power con- sumption W	Current value A	Connection	Weight kg
IX-B007 TC/TE	R	0.0075 - 7.5	1.7	17	0.4	R1/2	3.5
	N					1/2 NPT	
	G		G3/4				
	T		Tube* ²				
	F		Flange* ³				
IX-B007 S6	R	0.0075 - 7.5* ⁴	1.7	17	0.4	Rc3/8	4.5
	N		3/8 FNPT			6.0	
	FJ		JIS 10K 15A				
	FD		DIN PN10 DN15				
	FA		ANSI 150 lb 1/2"				
IX-B015 TC/TE	R	0.015 - 15	1.0	17	0.4	R1/2	3.5
	N					1/2 NPT	
	G		G3/4				
	T		Tube* ²				
	F		Flange* ³				
IX-B015 S6	R	0.015 - 15* ⁴	1.0	17	0.4	Rc3/8	6.0
	N					3/8 FNPT	
	FJ		JIS 10K 15A				
	FD		DIN PN10 DN15				
	FA		ANSI 150 lb 1/2"				
IX-B030 TC/TE	R	0.030 - 30	0.6	19	0.5	R1/2	3.7
	N					1/2 NPT	
	G		G3/4				
	T		Tube* ²				
	F		Flange* ³				
IX-B030 S6	R	0.030 - 30* ⁴	0.6	19	0.5	Rc3/8	6.5
	N					3/8 FNPT	
	FJ		JIS 10K 15A				
	FD		DIN PN10 DN15				
	FA		ANSI 150 lb 1/2"				
IX-B045 TC/TE	R	0.045 - 45	0.4	19	0.5	R1/2	3.7
	N					1/2 NPT	
	G		G3/4				
	T		Tube* ²				
	F		Flange* ³				
IX-B045 S6	R	0.045 - 45* ⁴	0.4	19	0.5	Rc3/8	6.5
	N					3/8 FNPT	
	FJ		JIS 10K 15A				
	FD		DIN PN10 DN15				
	FA		ANSI 150 lb 1/2"				

*The above information is based on pumping clean water at rated voltage and ambient temperature.

*Pressure overload protection will stop operation when a discharge pressure has risen 1.2 to 1.5 times higher than the maximum level.

*Allowable room temperature: 0-50°C (32-122°F)

*Allowable liquid temperature: 0-50°C (32-122°F)

*Allowable power voltage deviation: Within ±10% of the rated range

*Ambient humidity: 30-90%RH (non condensing)

*Noise level: 70dB(A) for the TC/TE types
80dB (A) for the S6 type

*¹ Rather than this value, observe the maximum allowable pressure of the tube to be used.

*² 1/4"×3/8" tubes (IX-B 007/015 TC/TE) or 3/8"×1/2" tubes (IX-B 030/045 TC/TE) are available.

*³ The common flange for the JIS10K15A, DIN PN10 DN15, and ANSI 150lb 1/2" sizes.

*⁴ The recommended flow rate of the IX-B S6 type is limited to 1 to 100% range. This means that when the flow rate is set to 45L/H (100%), the IX-B045 S6 can catch up with that value and the actual flow rate can be at 45L/H . But then when the flow rate is set below 0.45L/H (1%), the pump may not be able to meet that low value and the actual flow rate can be lower than the 0.45L/H.

■ Control unit

Operation modes	MAN (Manual)		A flow rate is set with ↑ (Up) and ↓ (Down) keys.
	EXT	Analog preset	4-20/0-20/20-4/20-0mA (proportional control: flow by preset current patterns)
		Analog variable	0-20mADC (proportional control: flow by user current patterns)
		Pulse control* ¹	0.000625mL/PLS - 15.000000mL/PLS (B007)
			0.001250mL/PLS - 30.000000mL/PLS (B015)
			0.002500mL/PLS - 60.000000mL/PLS (B030)
			0.003750mL/PLS - 90.000000mL/PLS (B045)
		Batch control* ¹	0.625mL/PLS - 15.000L/PLS (B007)
			1.250mL/PLS - 30.000L/PLS (B015)
			2.500mL/PLS - 60.000L/PLS (B030)
			3.750mL/PLS - 90.000L/PLS (B045)
		Interval batch control* ¹	0-9day, 0-23hr, 1-59min
			0.625mL - 15.000L/PLS (B007)
1.250mL - 30.000L/PLS (B015)			
2.500mL - 60.000L/PLS (B030)			
Profibus control	3.750mL - 90.000L/PLS (B045)		
	Profibus-DP, Compliant to EN50170 (IEC61158)		
Monitors	LCD	16×2 backlit LCD	
	LED bar	Lights in white colour when the pump stops.	
		Lights in green colour when the pump runs.	
		Lights in orange colour when the Pre-STOP signal is input.	
Lights in red colour when Alarm OUT 1 or 2 is activated.			
Operation	Key-pads	⓪ (Start/Stop), MENU, ESC, ↵ (Enter), ↑ (Up), ↓ (Down), ← (Left) and → (Right) keys	
Control functions	STOP	Pump OFF at contact input* ²	
	PRIME	Max spm operation while the UP and DOWN keys are pressed.	
	Keypad lock	PIN number entry disables the function.	
	Interlock	Pump OFF at contact input* ²	
	AUX	Pump ON at AUX speed at contact input	
	Maximum flow rate setting	The max flow rate can be set at each control mode.	
	Buffer	Accumulates the entered external pulse signal with buffer ON.	
	Current value indication	An input current is displayed during operation in the ANA.V mode.	
Input	Stop/ Pre-STOP	No-voltage contact or open collector* ³	
	AUX	No-voltage contact or open collector* ³	
	Interlock	No-voltage contact or open collector* ³	
	Analog	0-20mADC (internal resistance is 200Ω.)	
	Pulse	No-voltage contact/open collector (max 100Hz, min ON time: 5msec)	
Output	Alarm (OUT 1)	No voltage contact (mechanical relay) 250VAC 3A (resistive load) Enable or disable the Batch Complete* ⁴ , STOP, Pre-STOP, Interlock, Leak Detection (default: ON) and Motor Overload (/Drive Error).	
	Alarm (OUT 2)	No voltage contact (PhotoMOS relay) 24VAC/DC 0.1A (resistive load) Enable or disable the Volume Prop. PLS* ⁵ , Batch Complete* ⁴ , STOP, Pre-STOP, Interlock (default: ON), Leak Detection and Motor Overload (/Drive Error).	
	Power supply	12VDC 30mA or below	
	Analog	User current patterns of 0-20mADC (allowable load resistance: 300Ω)	
Power voltage* ⁶		100-240VAC 50/60Hz	

*¹ For these control modes, the calibrated flow volume per shot is applied to the minimum settable flow volume per shot.

*² The setting can be changed to "pump ON at contact input".

*³ The maximum applied voltage from the IX to an external contact is 12V at 5mA. When using a mechanical relay, its minimum application load should be 5mA or below.

*⁴ If the "Batch Complete" output is set to enabled, other output functions turn disabled.

*⁵ If the "Volume Prop. PLS" output is set to enabled, other output functions turn disabled.

*⁶ Observe the specified power voltage range or failure may result. The allowable power voltage range is 90-264VAC.

*⁷ An Iwaki Profibus converter is needed to establish the Profibus control. Purchase separately.

■ Power cable

Conduction section area	18AWG Triplex cable (L/N/PE)
Length	1950 [mm]
Standard	U type : SJT W-A U2 type : SJT W
Terminal treatment	Plug

■ Body colour

Blue	Munsell colour system 7.5PB 3/8
------	---------------------------------

Outer dimensions

■ IX-B007/-B015/-B030/-B045 TC/TE R/N

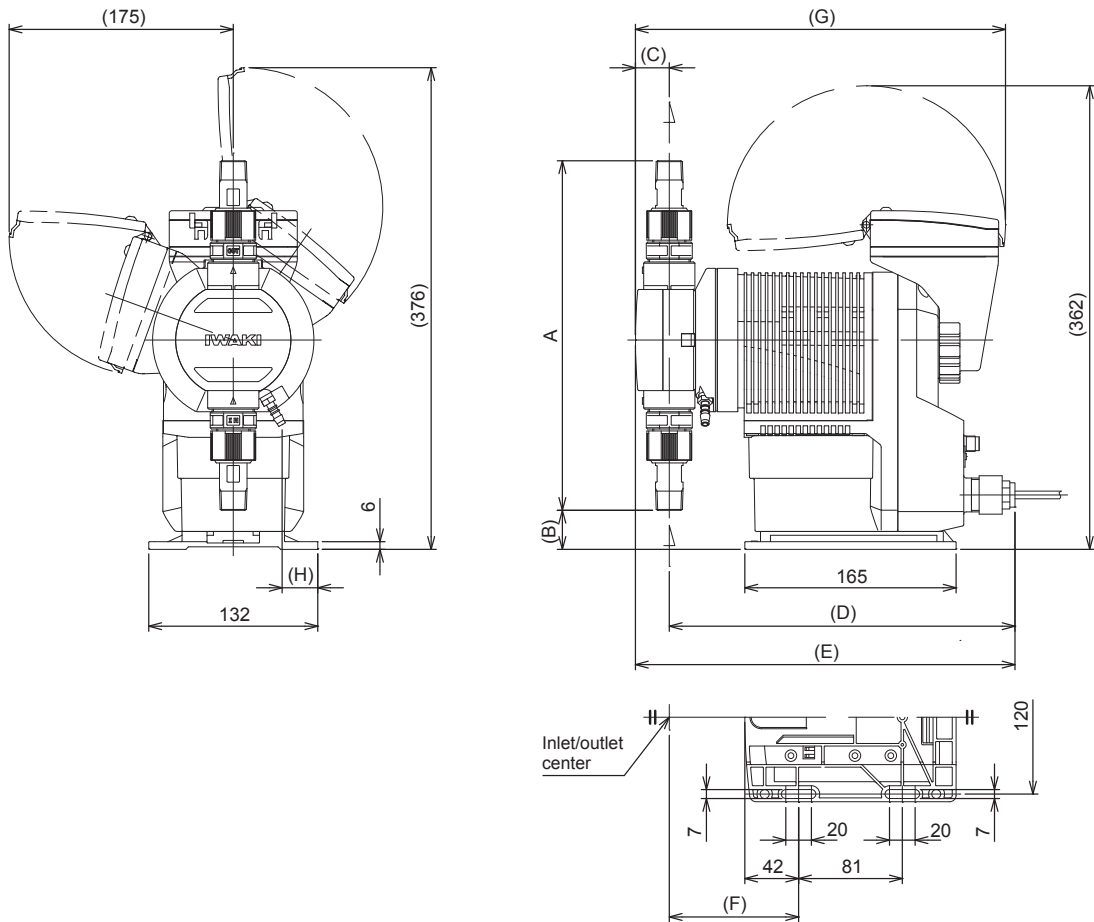

	A	B	C	D	E	F	G	H
IX-B007	240	45	24.3	267	291	98	284	29
IX-B015	249	41	24.3	267	291	98	284	29
IX-B030/-B045	273	30	26.4	270	296	101	289	28

■ IX-B007/-B015/-B030/-B045 TC/TE G

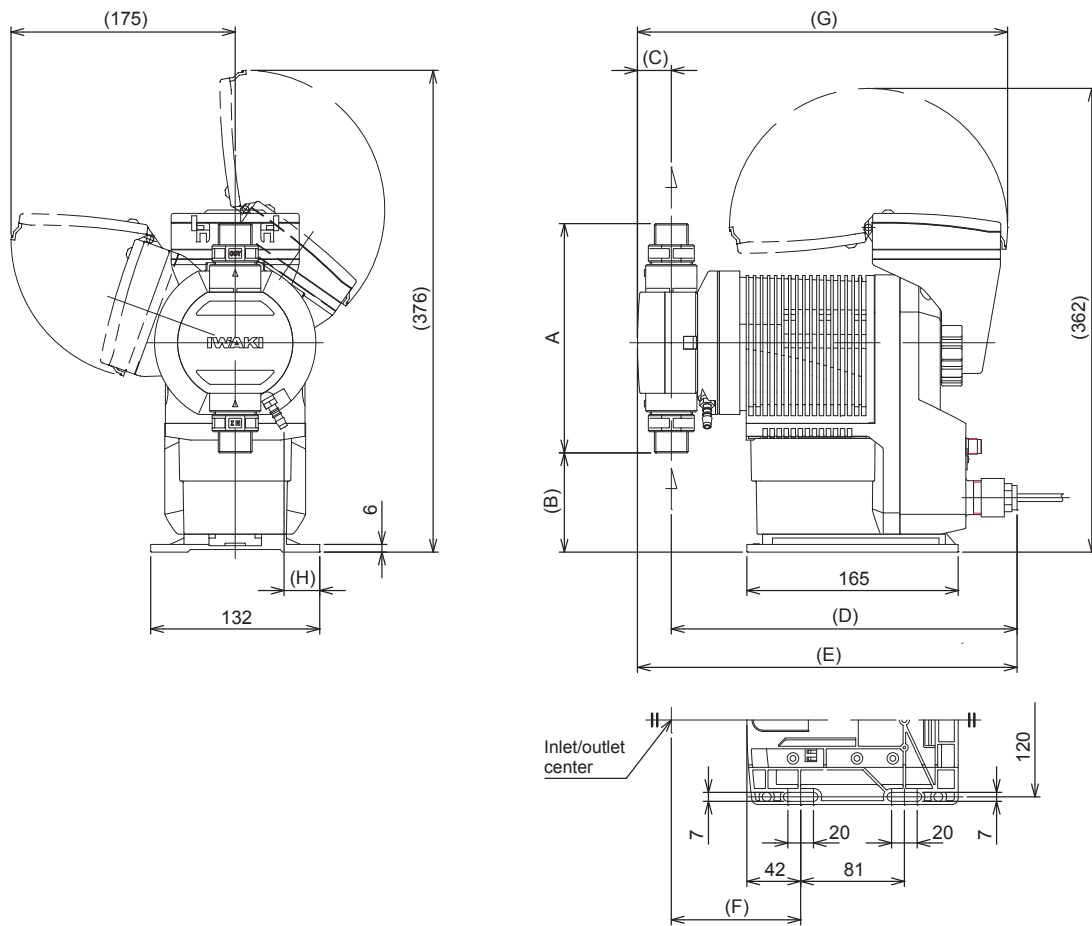

	A	B	C	D	E	F	G	H
IX-B007	146	92	24.3	267	291	98	284	29
IX-B015	155	88	24.3	267	291	98	284	29
IX-B030/-B045	179	77	26.4	270	296	101	289	28

■ IX-B007/-B015/-B030/-B045 TC/TE F

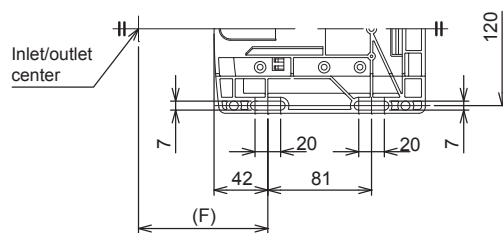
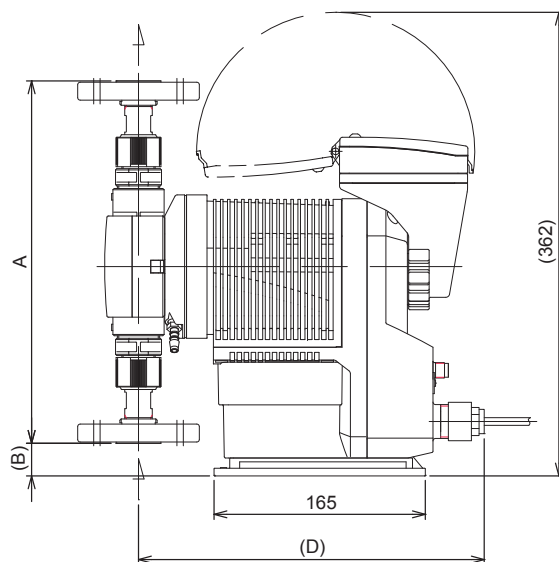
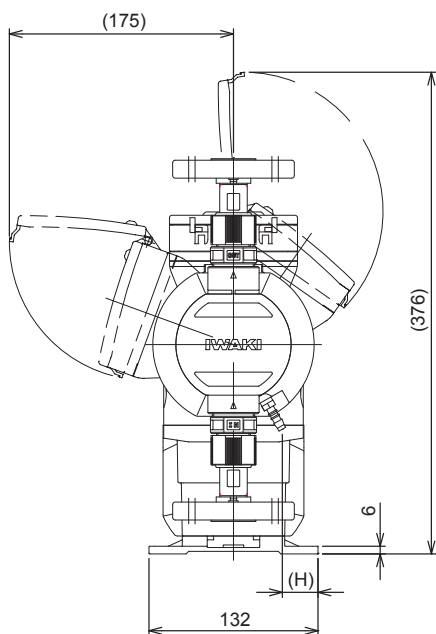

	A	B	C	D	E	F	G	H
IX-B007	250	40	-	267	-	98	-	29
IX-B015	259	36	-	267	-	98	-	29
IX-B030/-B045	283	25	-	270	-	101	-	28

■ IX-B007/-B015/-B030/-B045 TC/TE T

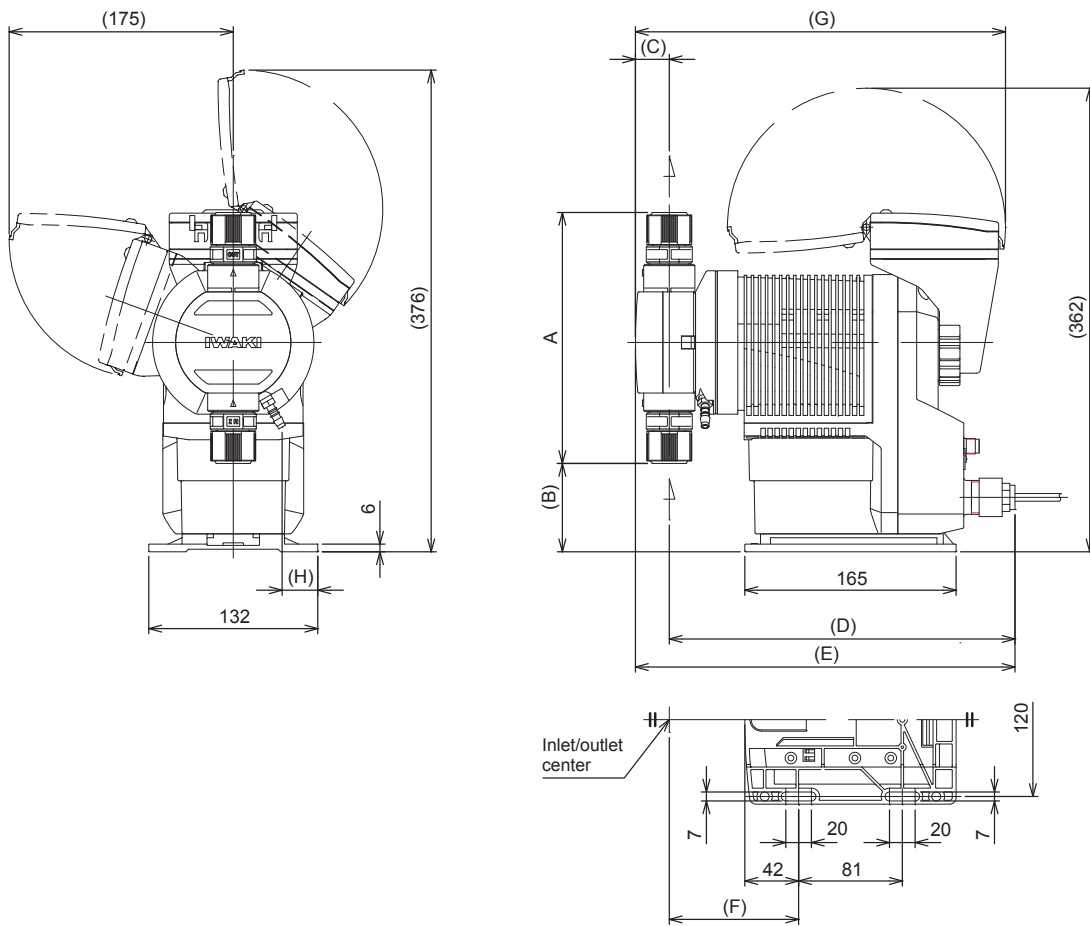

	A	B	C	D	E	F	G	H
IX-B007	168	81	24.3	267	291	98	284	29
IX-B015	177	77	24.3	267	291	98	284	29
IX-B030/-B045	201	66	26.4	270	296	101	289	28

■ IX-B007/-B015/-B030/-B045 S6 R/N

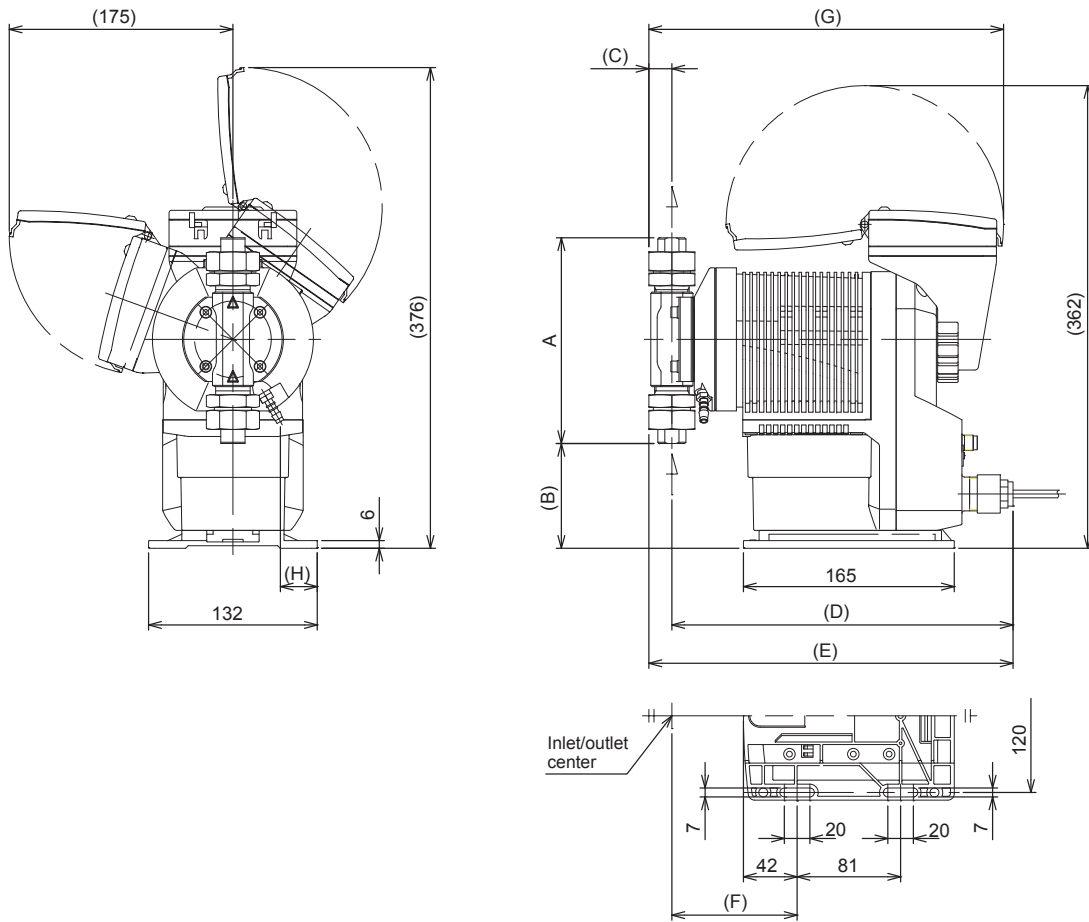

	A	B	C	D	E	F	G	H
IX-B007/-B015	161	82	18	267	285	94.5	277.6	29
IX-B030/-B045	177	72	19	269.5	288.5	97	281	28

■ IX-B007/-B015/-B030/-B045 S6 FJ/FD/FA

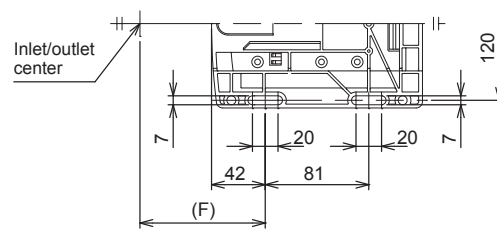
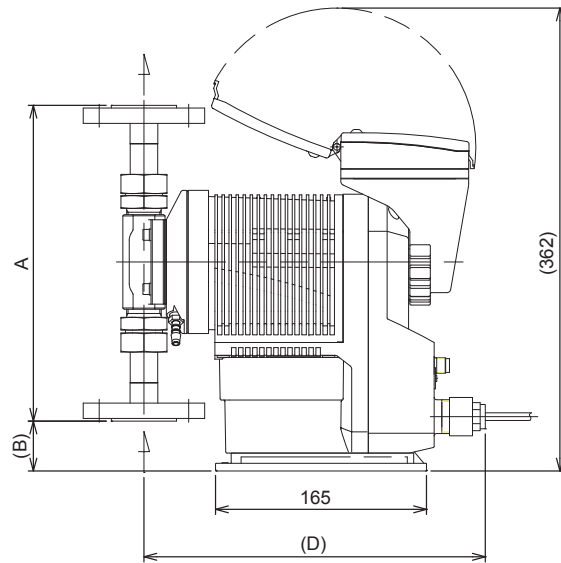
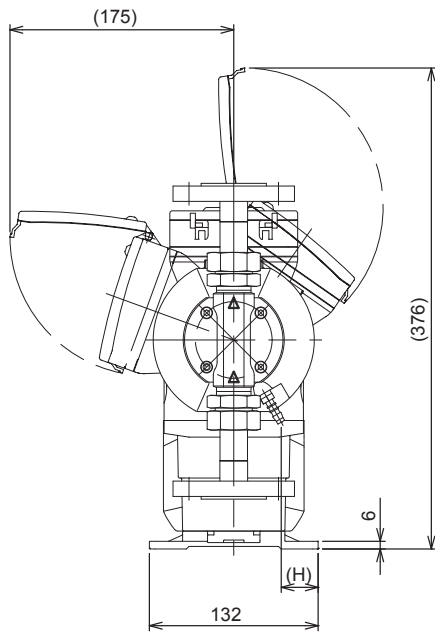

	A	B	C	D	E	F	G	H
IX-B007/-B015	247	39	-	267	-	94.5	-	29
IX-B030/-B045	263	29	-	269.5	-	97	-	28

Anchorage points guide (Wall-mount use of the base)

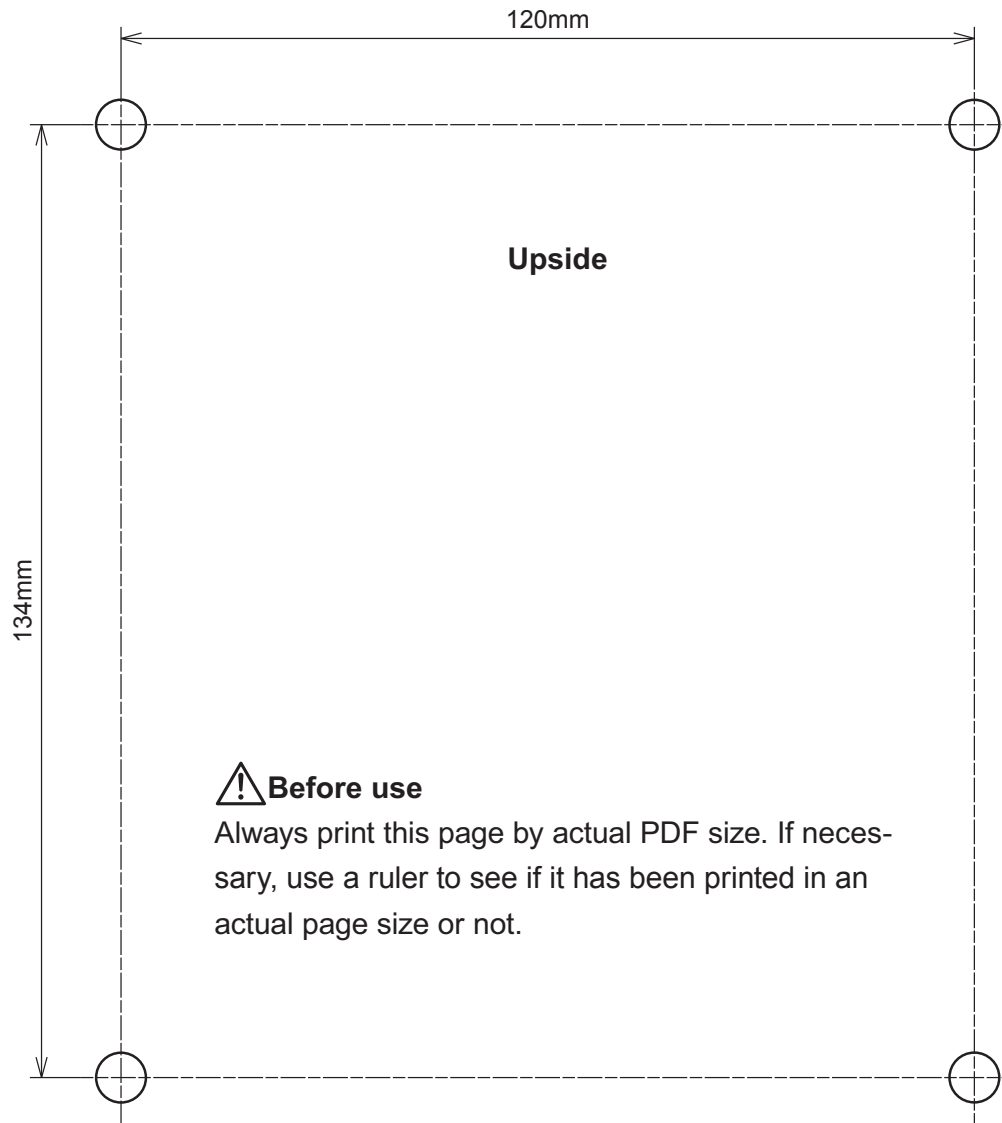

*Use this page and drill the wall for wall mounting with the base of the pump. Copy or cut as necessary. Use a proper drill size for the wall to have M6 anchor nut. Always select the rigid wall for wall-mounting of the pump. Do not drop. It's not the manufacturer's responsibility for any failure or damage resulting from a dropped pump.

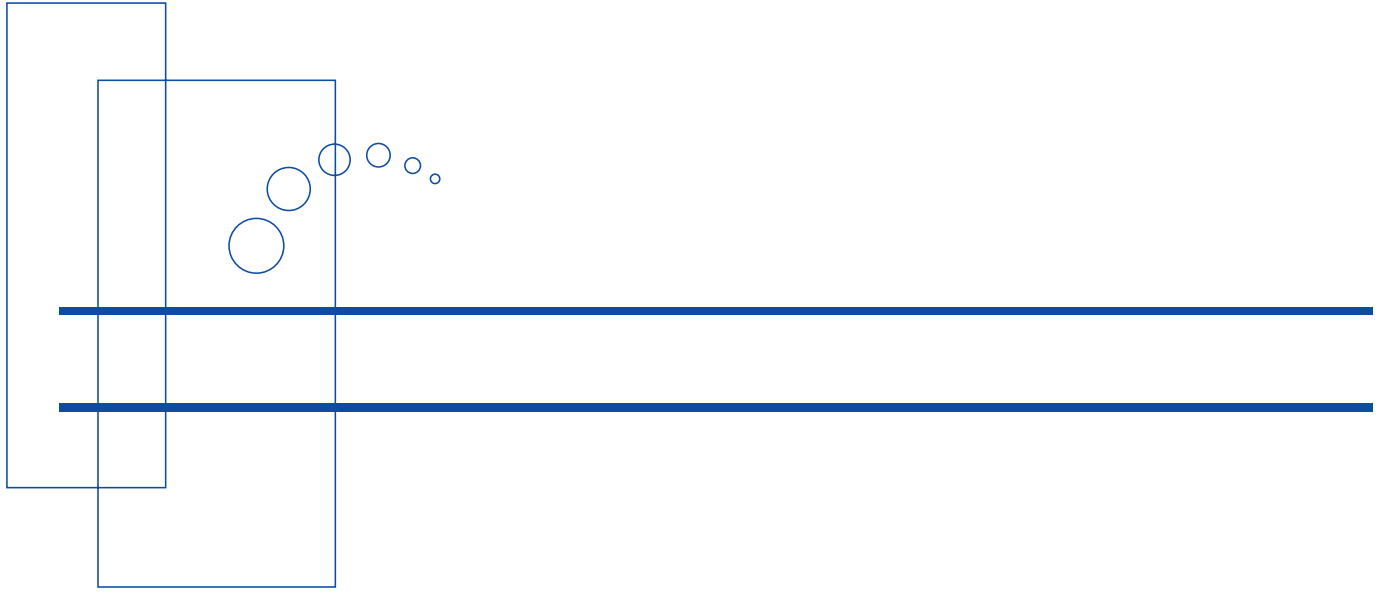

<https://www.iwakipumps.jp>
IWAKI CO.,LTD. 6-6 Kanda-Sudacho 2-chome Chiyoda-ku Tokyo 101-8558 Japan
TEL: +81 3 3254 2935 FAX: +81 3 3252 8892

European office / IWAKI Europe GmbH
TEL: +49 2154 9254 0 FAX: +49 2154 9254 48

Germany / IWAKI Europe GmbH
TEL: +49 2154 9254 50 FAX: +49 2154 9254 55

Holland / IWAKI Europe GmbH (Netherlands Branch)
TEL: +31 74 2420011 FAX: +49 2154 9254 48

Italy / IWAKI Europe GmbH (Italy Branch)
TEL: +39 0444 371115 FAX: +39 0444 335350

Spain / IWAKI Europe GmbH (Spain Branch)
TEL: +34 93 37 70 198 FAX: +34 93 47 40 991

Poland / IWAKI Europe Branch EAST
TEL: +48 12 347 0755 FAX: +48 12 347 0900

Belgium / IWAKI Belgium N.V.
TEL: +32 13 670200 FAX: +32 13 672030

Denmark / IWAKI Nordic A/S
TEL: +45 48 242345 FAX: +45 48 242346

Finland / IWAKI Suomi Oy
TEL: +358 10 201 0490

France / IWAKI France S.A.
TEL: +33 1 69 63 33 70 FAX: +33 1 64 49 92 73

Norway / IWAKI Norge AS
TEL: +47 23 38 49 00 FAX: +47 23 38 49 01

Sweden / IWAKI Sverige AB
TEL: +46 8 511 72900 FAX: +46 8 511 72922

U.S.A. / IWAKI America Inc.
TEL: +1 508 429 1440 FAX: +1 508 429 1386

Argentina / IWAKI America Inc. (Argentina Branch)
TEL: +54 11 4745 4116

Brazil / IWAKI Do Brasil Comercio De Bombas Hidraulicas LTDA.
TEL/FAX: +55 19 3244 5900

Singapore / IWAKI Singapore Pte Ltd.
TEL: +65 6316 2028 FAX: +65 6316 3221

Indonesia / IWAKI Singapore (Indonesia Office)
TEL: +62 21 6906606 FAX: +62 21 6906612

Malaysia / IWAKIm SDN. BHD.
TEL: +60 3 7803 8807 FAX: +60 3 7803 4800

Australia / IWAKI Pumps Australia Pty Ltd.
TEL: +61 2 9899 2411 FAX: +61 2 9899 2421

China (Hong Kong) / IWAKI Pumps Co., Ltd.
TEL: +852 2607 1168 FAX: +852 2607 1000

China (Guangzhou) / GFTZ IWAKI Engineering & Trading Co., Ltd.
TEL: +86 20 84350603 FAX: +86 20 84359181

China / IWAKI Pumps (Shanghai) Co., Ltd.
TEL: +86 21 6272 7502 FAX: +86 21 6272 6929

Korea / IWAKI Korea Co., Ltd.
TEL: +82 2 2630 4800 FAX: +82 2 2630 4801

Taiwan / IWAKI Pumps Taiwan Co., Ltd.
TEL: +886 2 8227 6900 FAX: +886 2 8227 6818

Thailand / IWAKI (Thailand) Co., Ltd.
TEL: +66 2 322 2471 FAX: +66 2 322 2477